

Resonance Structure in the $\gamma\gamma$ and $\pi^0\pi^0$ Systems

Kh.U. Abraamyan, A.V. Friesen, M.A. Kozhin, and S.G. Reznikov

VBLHEP JINR, Dubna, Russia

M.I. Baznat and K.K. Gudima

Institute of Applied Physics, Kishinev, Moldova

S.A. Lebedev, G.A. Ososkov

LIT JINR, Dubna, Russia

M.A. Nazarenko

MIREA, Moscow, Russia

A.N. Sissakian, A.S. Sorin, and V.D. Toneev

BLTP JINR, Dubna, Russia

The plan of the report

The experimental results:

1. The first observation;
2. Checks;
3. The second observation

Data simulation.

Possible mechanisms of the observed effect.

Preliminary results on observation of the resonance in $\pi^0\pi^0$ system.

Conclusion, outlook.

PHOTON-2 setup on internal beams of the NUCLOTRON

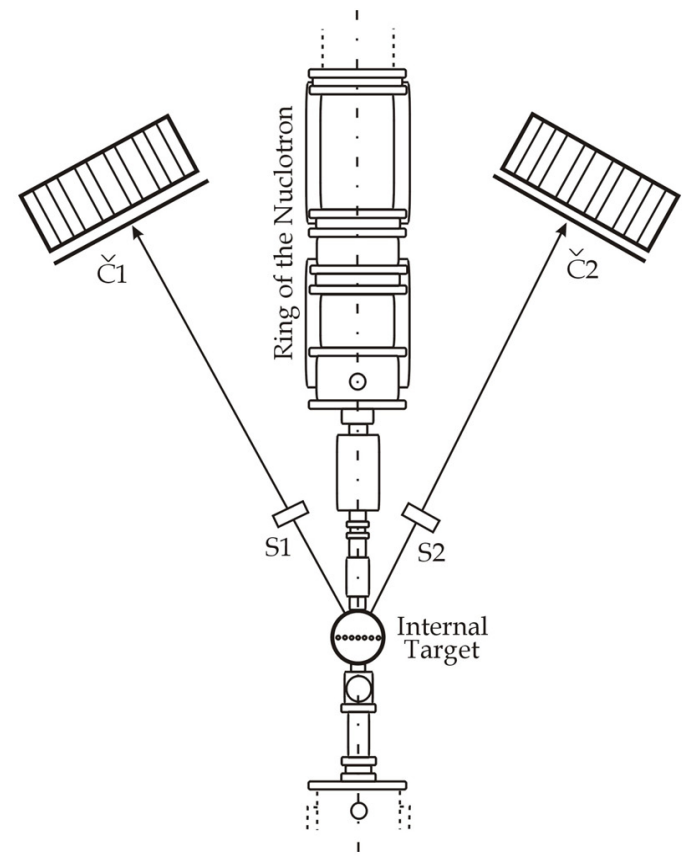
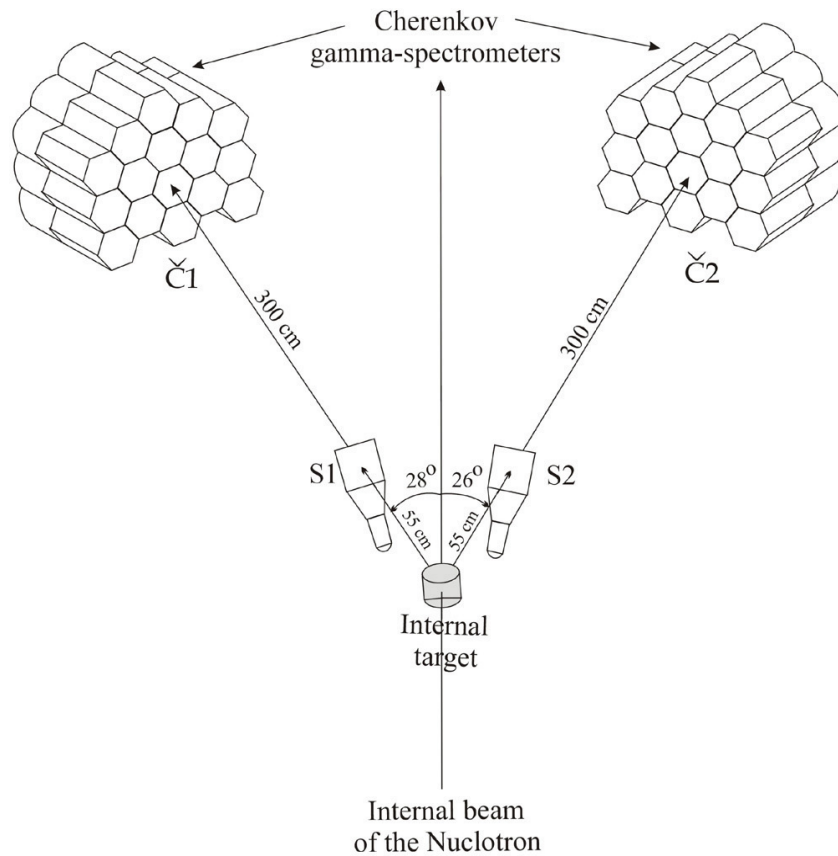

The block-scheme of electronic equipment

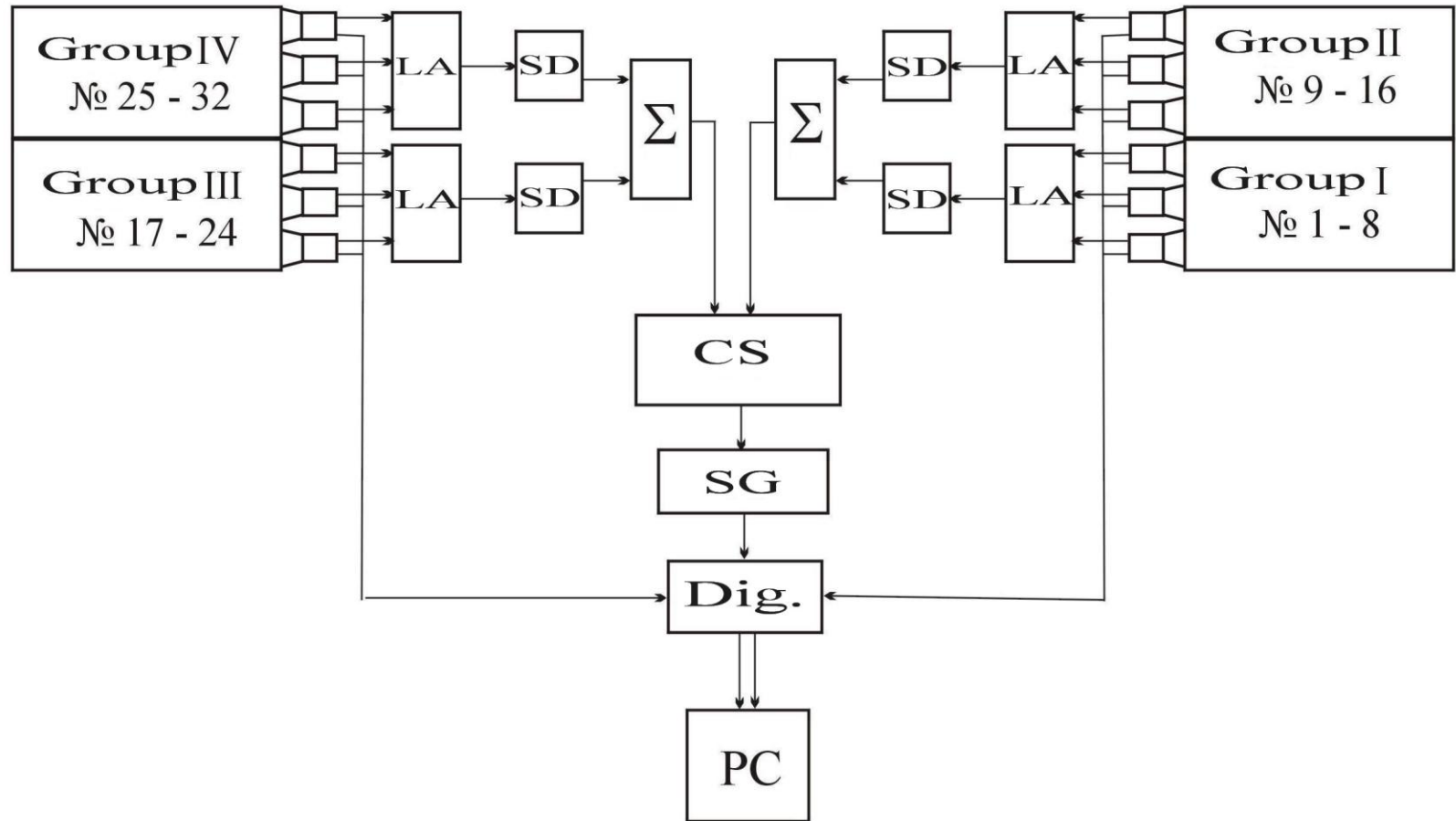

Invariant mass distributions of $\gamma\gamma$ pairs without (left) and with (right) the background subtraction.
The reaction $p(5.5 \text{ GeV}/c)+C$, minimal cuts: $E_\gamma \geq 50 \text{ MeV}$

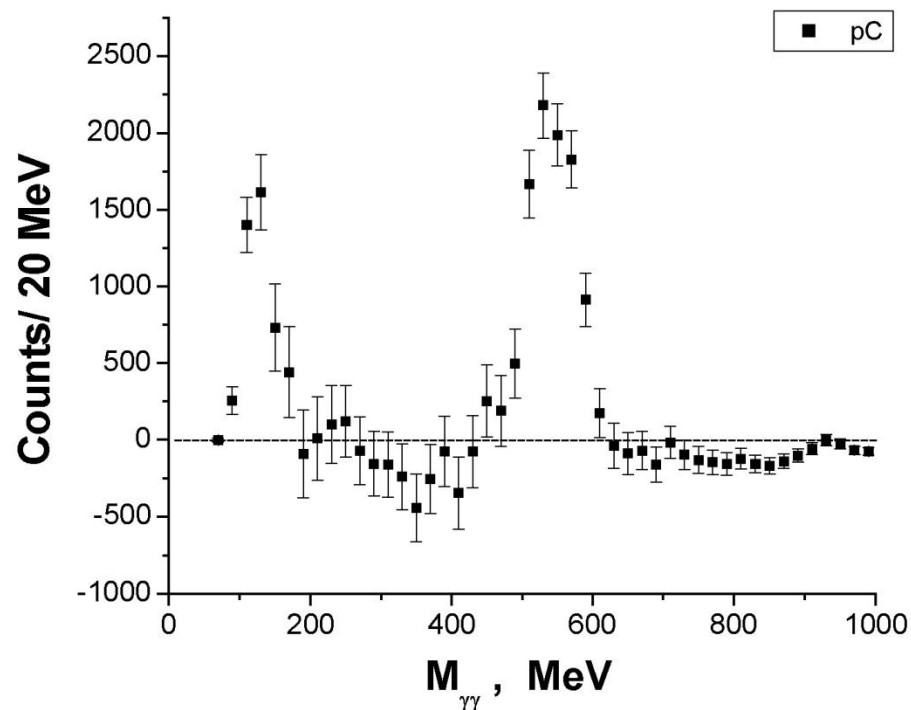
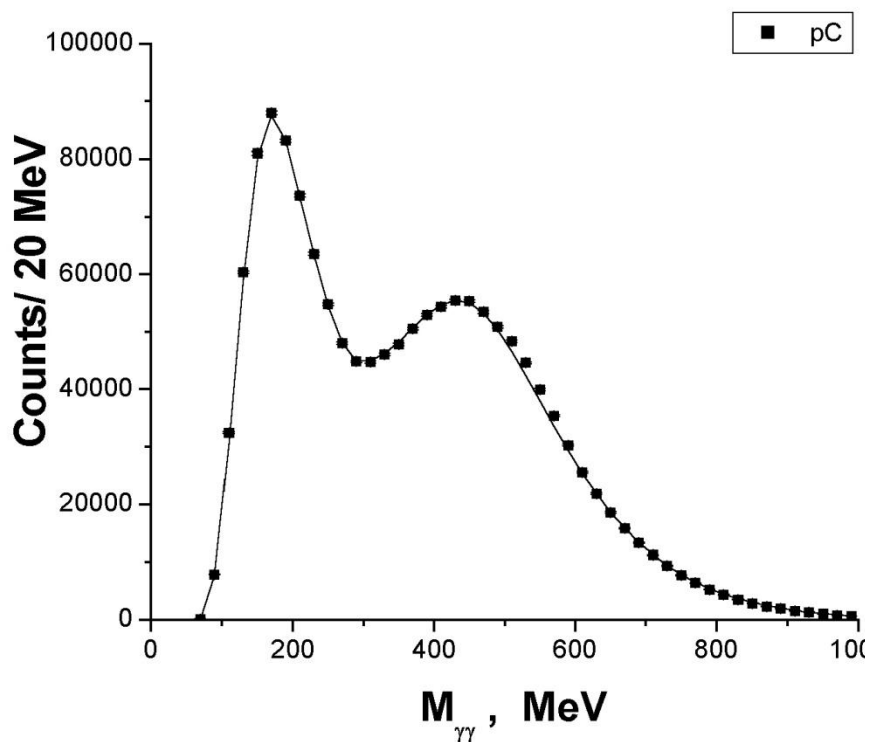

Invariant mass distributions of $\gamma\gamma$ pairs without (left) and with (right) the background subtraction.
 The reaction $d(5.5 \text{ GeV}/c)+C$, minimal cuts: $E_\gamma \geq 50 \text{ MeV}$

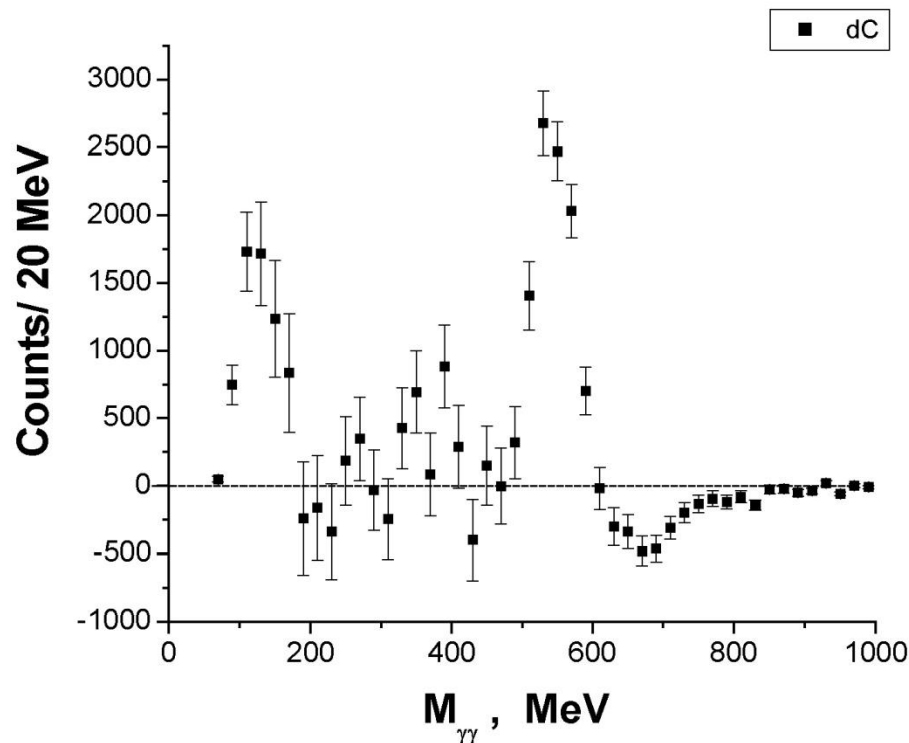
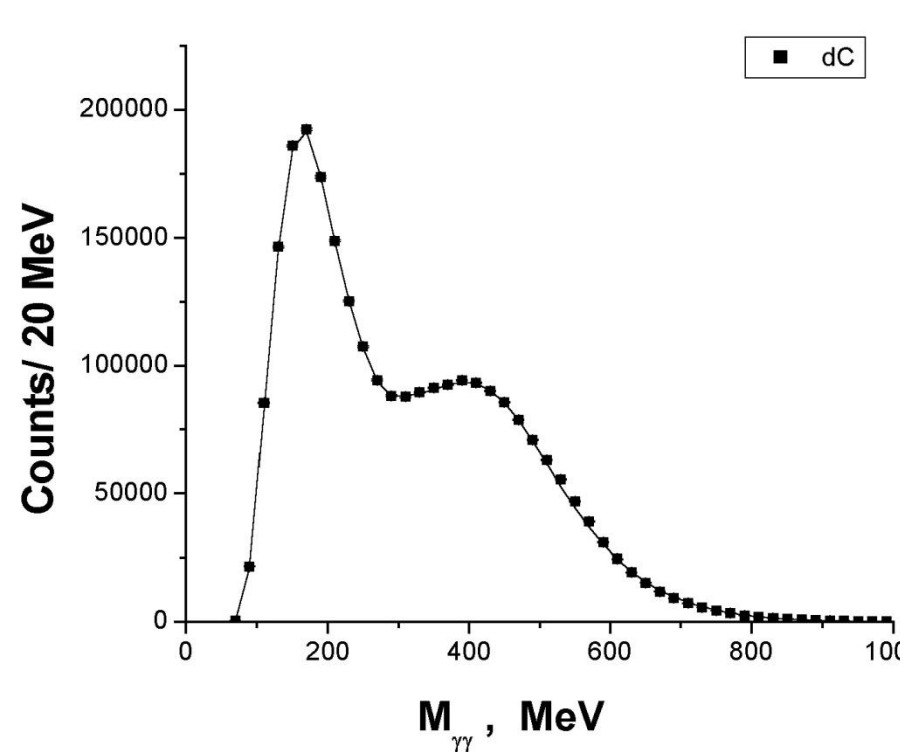

The selection criteria

- (1) the number of photons in an event, $N = 2$ or N
- (2) the energies of photons, $E \geq 0.5$ MeV;
- (3) the summed energy in real and random events ≤ 1.5 GeV.

The first observation (nucl-ex/0607027; PR C80, 2009, p.034001)

Invariant mass distributions of $\gamma\gamma$ pairs without (upper panels) and with (bottom panels) the background subtraction.

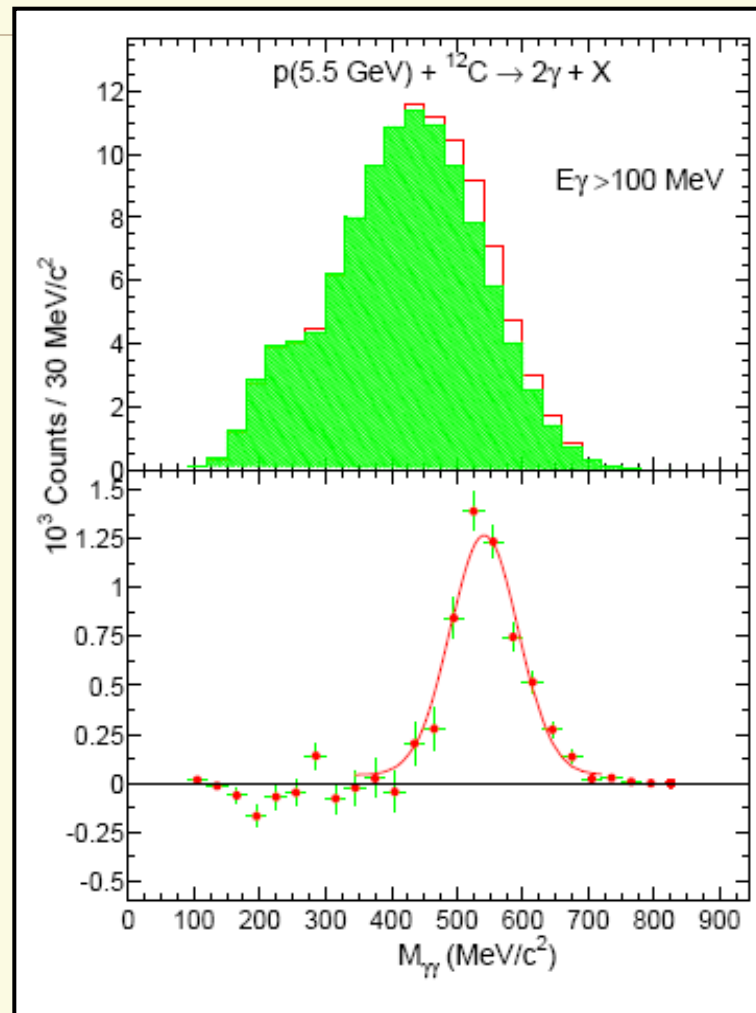
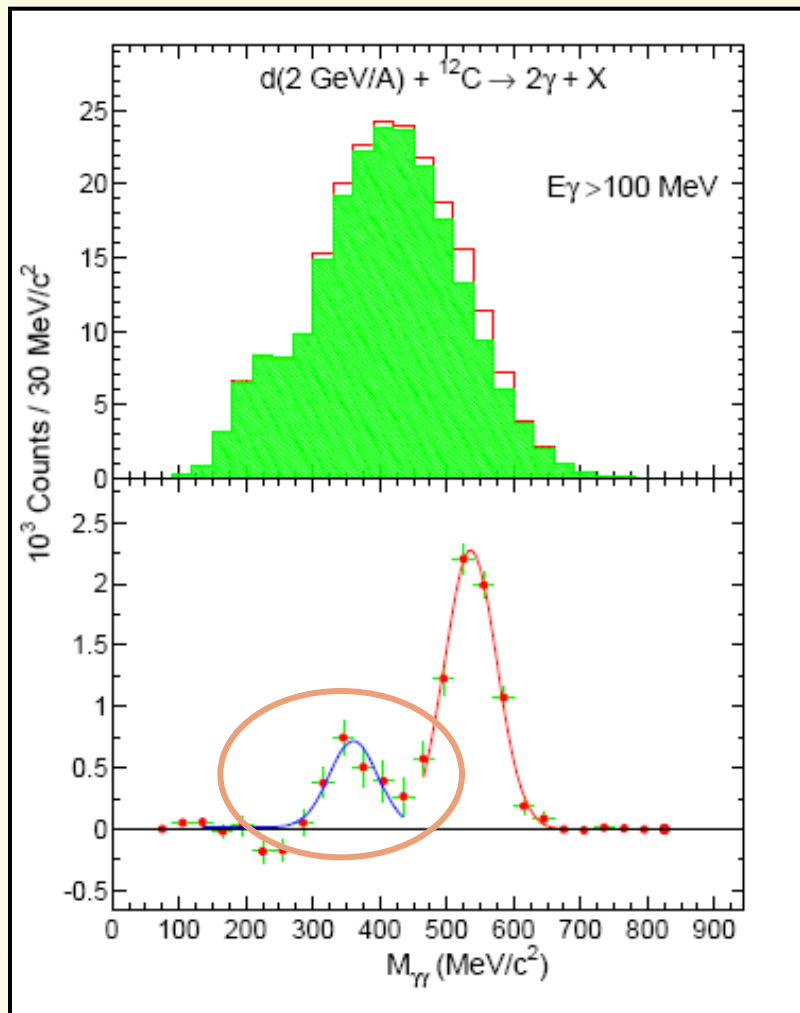

Check of the observed effect

The dominant part of background comes from the $\pi^0 \rightarrow \gamma\gamma$ decay. Other sources of background are charged particles as well as neutrons and particles from a general background in the accelerator hall.

1. The contribution of the general background in the experimental hall was estimated from the measurements with empty target: this source contributes less than 1% and is quite smoothly distributed with respect to $M_{\gamma\gamma}$. (sl. №33)
2. Contributions of the given sources were estimated by special measurements with and without veto-detectors $S1$ and $S2$ and by comparison of data obtained at different beam intensities. The total contribution of above sources is less than **10%** and becomes negligible ($< 1\%$) after subtraction of event mixing background (sl. №34÷36)

Check of the observed effect

3. To elucidate the nature of the detected enhancement , we investigate the dependence of its position and width on:
the opening angle of two photons, their energy selection level, ratio of their energies, the number of detected photons (the energy of 3-th photon) (sl. №37÷40)
4. Pair distributions over the opening angle $\Theta_{\gamma\gamma}$ for different intervals of the sum of two-photon energy. (sl. №41)
5. Investigations of systematic errors. (sl. №42,43)
6. Similar analysis within the wavelet method. (sl. №44)
7. Comparisons with another experiments. (sl. №45÷52)
8. Model simulation under the experimental conditions (see below).

The second observation (JINR, P1-2009-155 ; ДАН, 2010, т.431, с. 468; Doklady Physics, v.55, p.161)

Invariant mass distributions in $d(2\text{GeV}/n)+\text{C}$ and $d(3\text{GeV}/n)+\text{Cu}$.

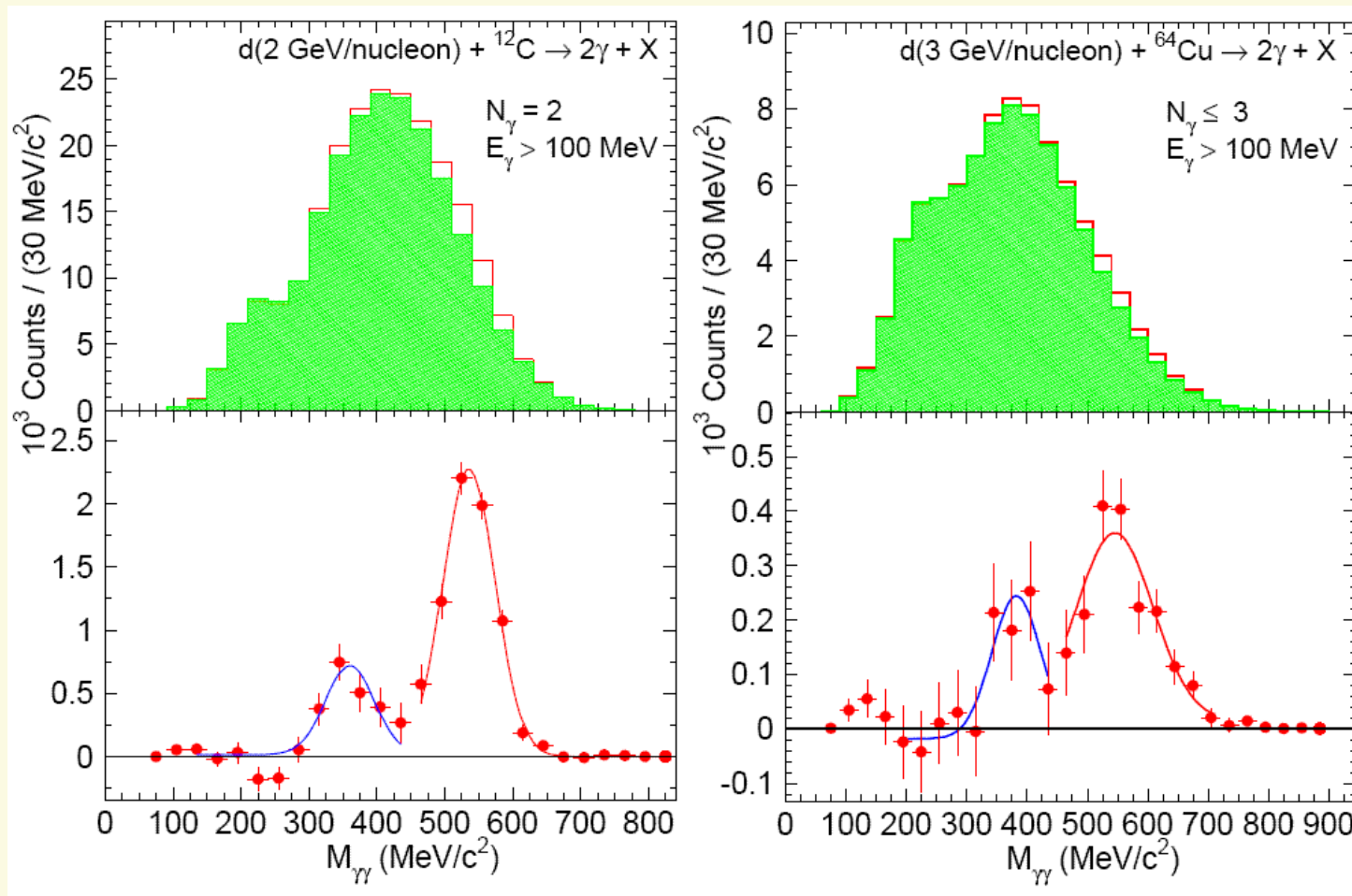

The resonance parameters from the experiment on $d\text{Cu}$ -interactions at 3.8 GeV/c per nucleon

$$M_{\gamma\gamma} = 382 \pm 13 \text{ MeV},$$

$$\Gamma = 62.0 \pm 37.2 \text{ MeV}$$

$$\sigma(d\text{Cu} \rightarrow R \rightarrow \gamma\gamma) = 273 \pm 7^{+320}_{-96} \text{ } \mu\text{b}.$$

Data simulation

- ❑ To simulate pC -, dC - and dCu - reactions we used a two-phases transport code [*K.K. Gudima et al. LANL Report LA-UR-01-6804, Los Alamos, 2001*]
- ❑ The following γ -decay channels are taken into account:
 - ✓ the direct decays of π^0, η, η' hadrons into two γ 's;
 - ✓ $\omega \rightarrow \pi^0 \gamma$;
 - ✓ $\Delta \rightarrow N \gamma$;
 - ✓ the Dalitz decays of $\eta \rightarrow \pi \pi \gamma$, $\eta \rightarrow \gamma e e$, $\pi^0 \rightarrow \gamma e e$;
 - ✓ $\eta' \rightarrow \rho^0 \gamma$, $\Sigma \rightarrow \Lambda \gamma$,
 - ✓ the πN and NN -bremsstrahlung.

The calculated $\gamma\gamma$ invariant mass distributions in pC (left) and dC (right) collisions for selected events with $N_\gamma = 2$.

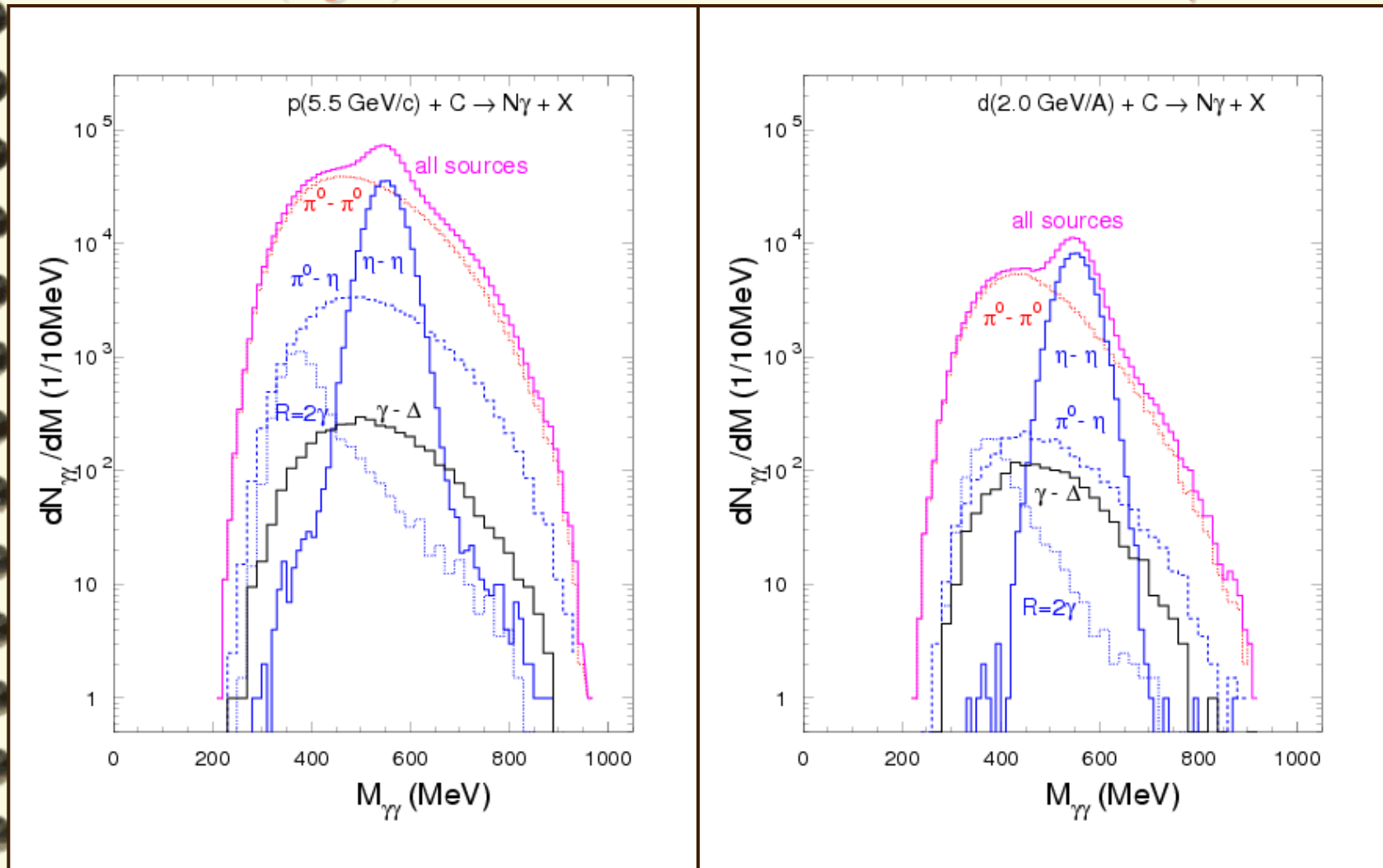

The invariant mass distributions of $\gamma\gamma$ pairs from the pC (left) and dC (right) reactions after background subtraction.

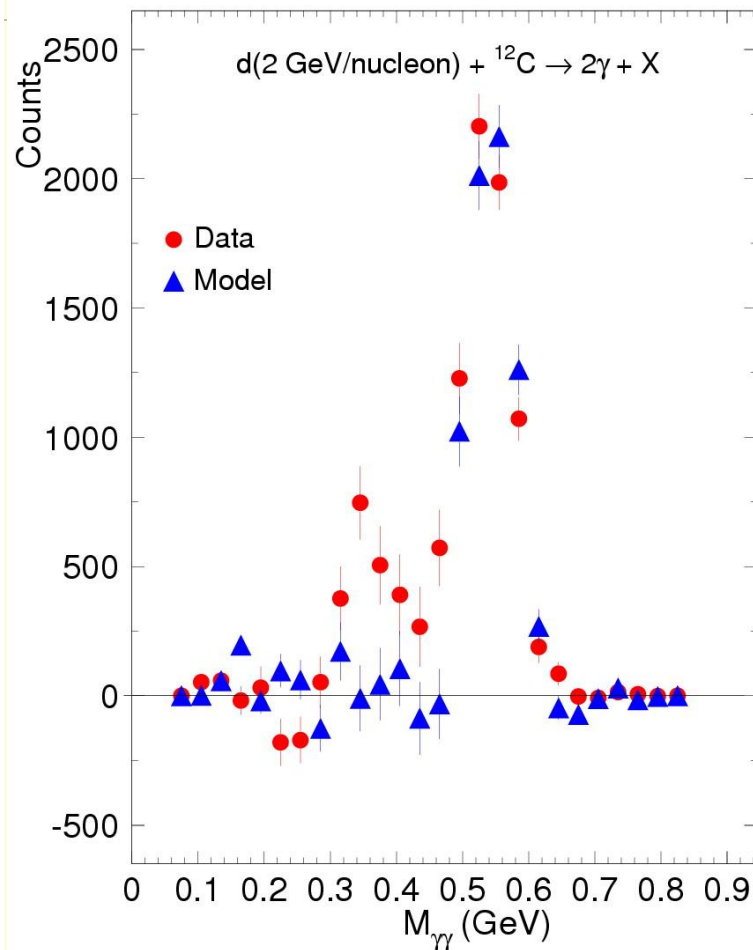
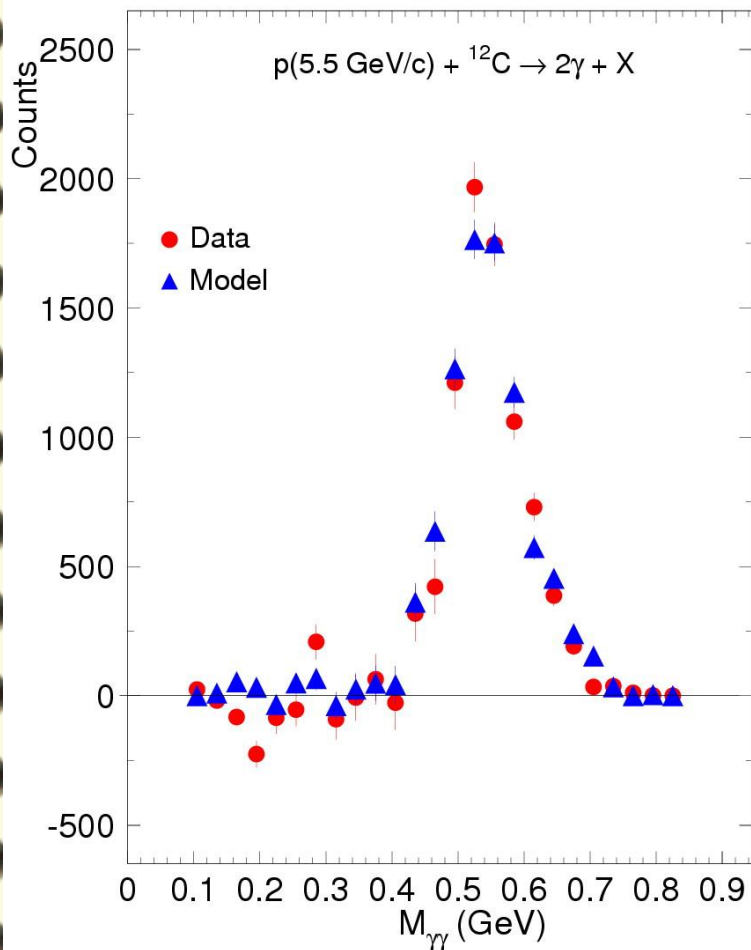

Invariant mass distribution of pion pairs from $\pi\pi$ -interactions in pC and dC collisions

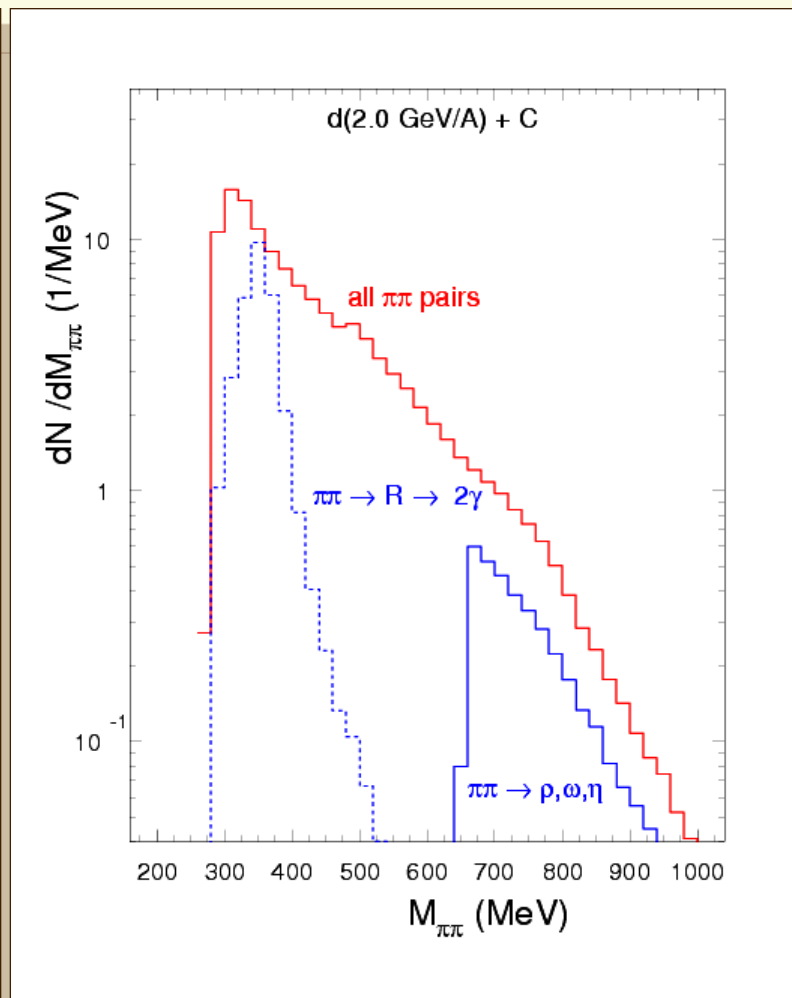
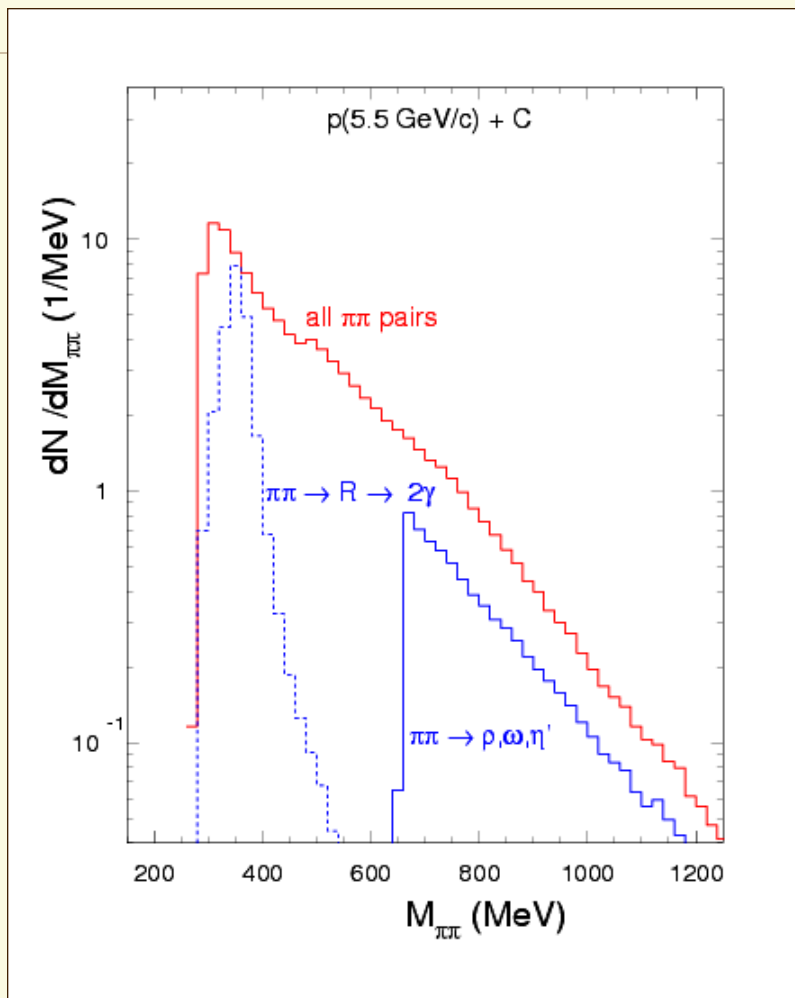

Experimental (circles) and simulated (triangles) data under the same conditions. The solid lines – contribution of photons from the R decay

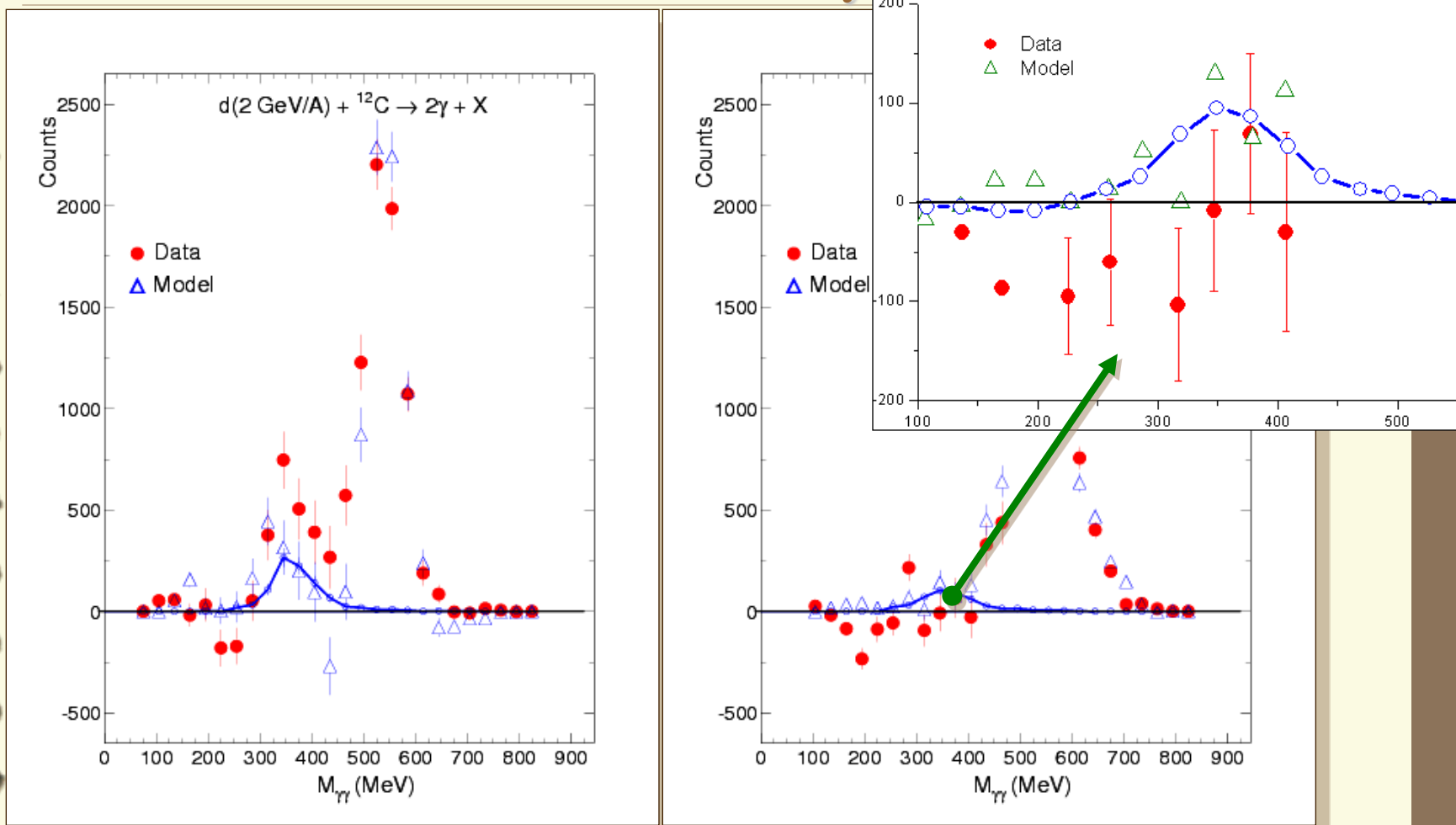

Dibaryon mechanism (I)

Recently the idea of nontrivial dibaryon state becomes more attractive. The proposed mechanism NN proceeds through a sequential emission of two photons: one is caused by production of the decoupled baryon resonance d^* , second is its subsequent decay.

A.S. Khrykin and S.B. Gerasimov, On a possible origin of a resonance-like structure in the two-
arXiv:0710.3331.

*A.S. Khrykin et al., **PRC64** (2001) 034002, **NPA721**(2003)625*

Dibaryon mechanism (II)

Some candidate for its realization might be a model of the intermediate σ -dressed dibaryon. In this model the short-range NN -interaction is described with the s -channel σ exchange associated with the intermediate dibaryon production treated as a σ -dressed six-quark bag. As the result we have decrease of the assumed σ - mass, it is estimated $M \sim 350 \div 380$ MeV. Therefore it should enhance the near-threshold pion and double-pion production. [*V.I.Kukulin et al. J.Phys.G30(2004)287, 30(2004),309*]

This mechanism is now under investigation.

Preliminary results
on observation of the resonance
in the invariant mass spectra of
two π^0 mesons

Two π^0 identification

$$S = (M_{ij} - m_{\pi})^2 / (\Delta M_{ij})^2 + (M_{kl} - m_{\pi})^2 / (\Delta M_{kl})^2$$

1. Minimal S

2. $|M_{ij} - m_{\pi}| \leq \delta; \quad |M_{kl} - m_{\pi}| \leq \delta$

$$\delta = 40 \text{ MeV}$$

The invariant mass spectra of two π^0

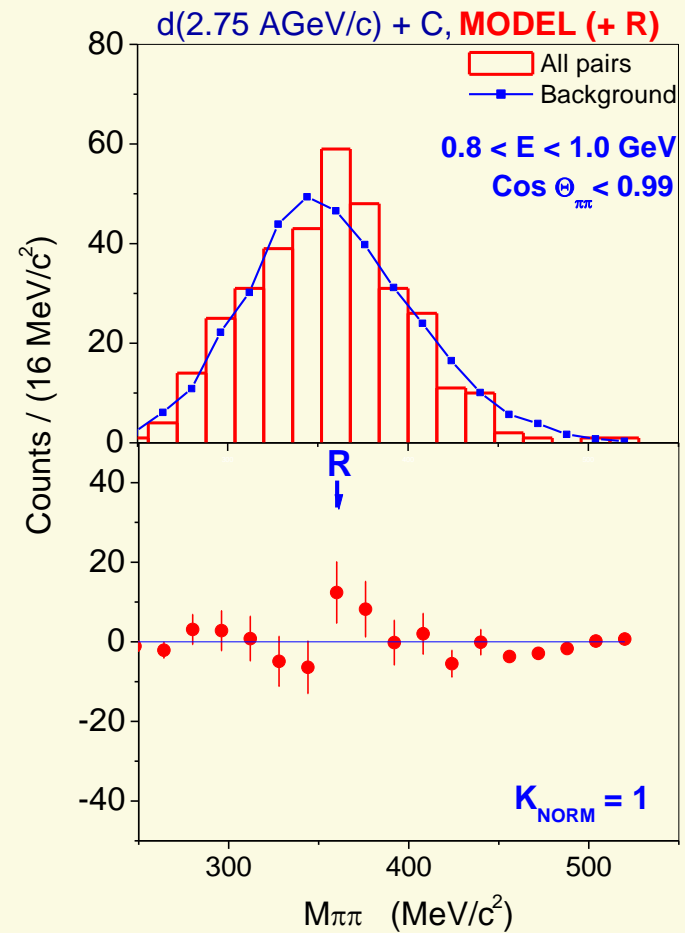
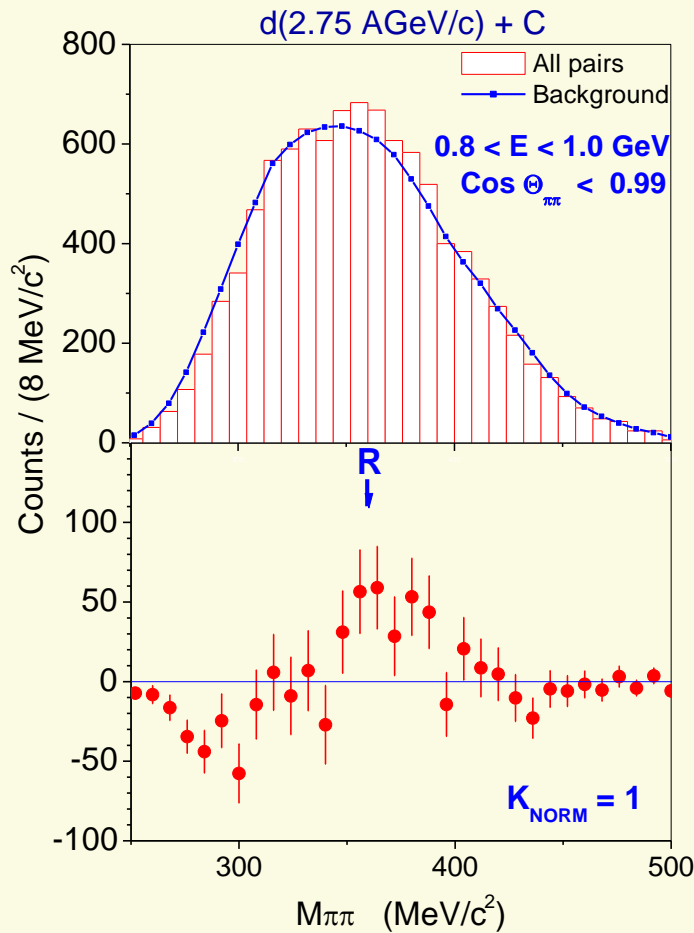

The invariant mass spectra of two π^0

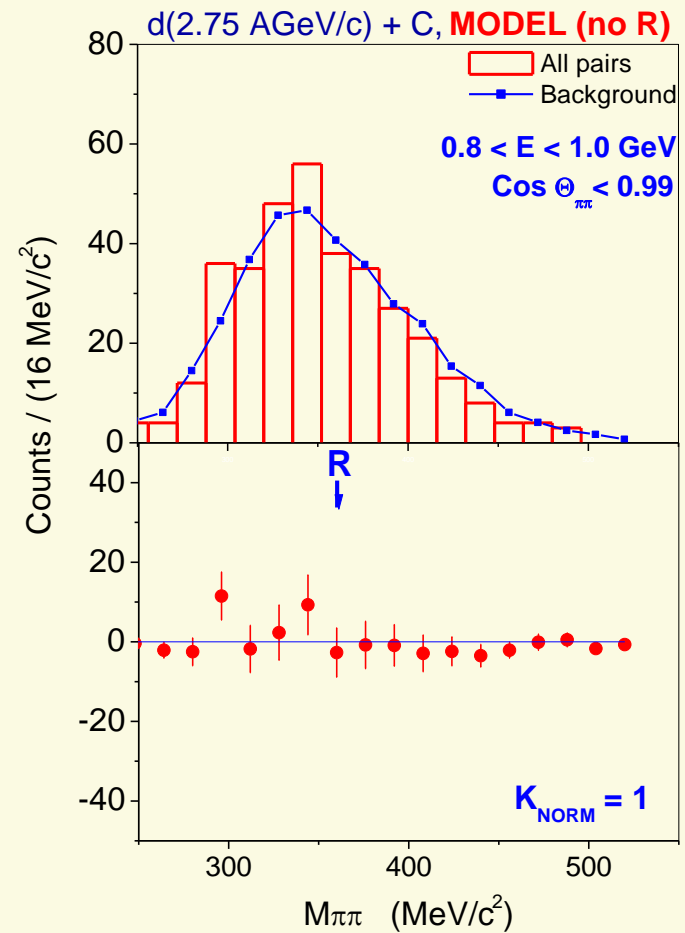
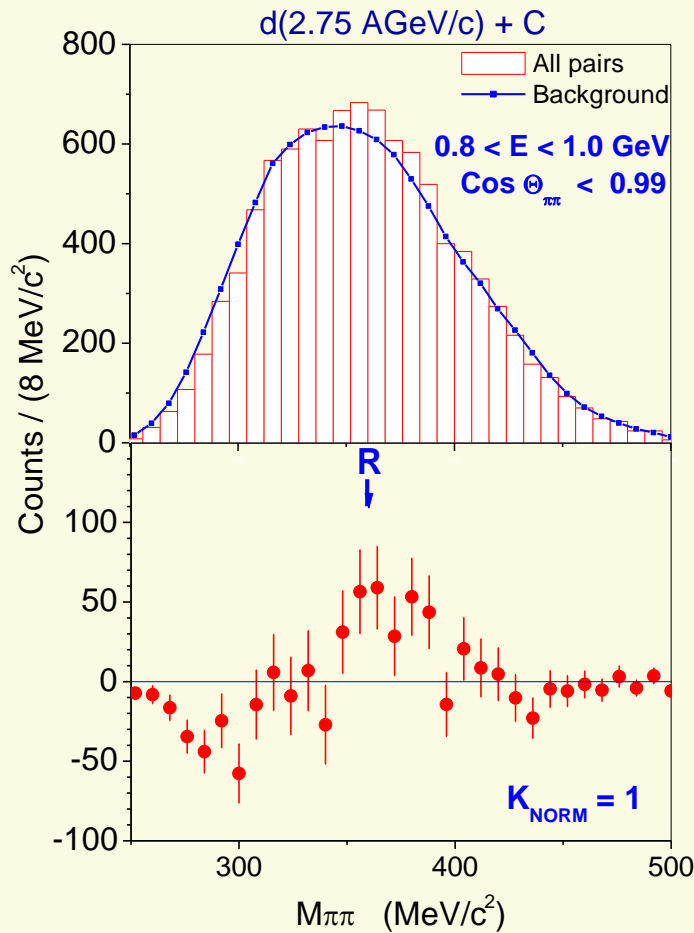

Preliminary

The invariant mass spectra of two π^0

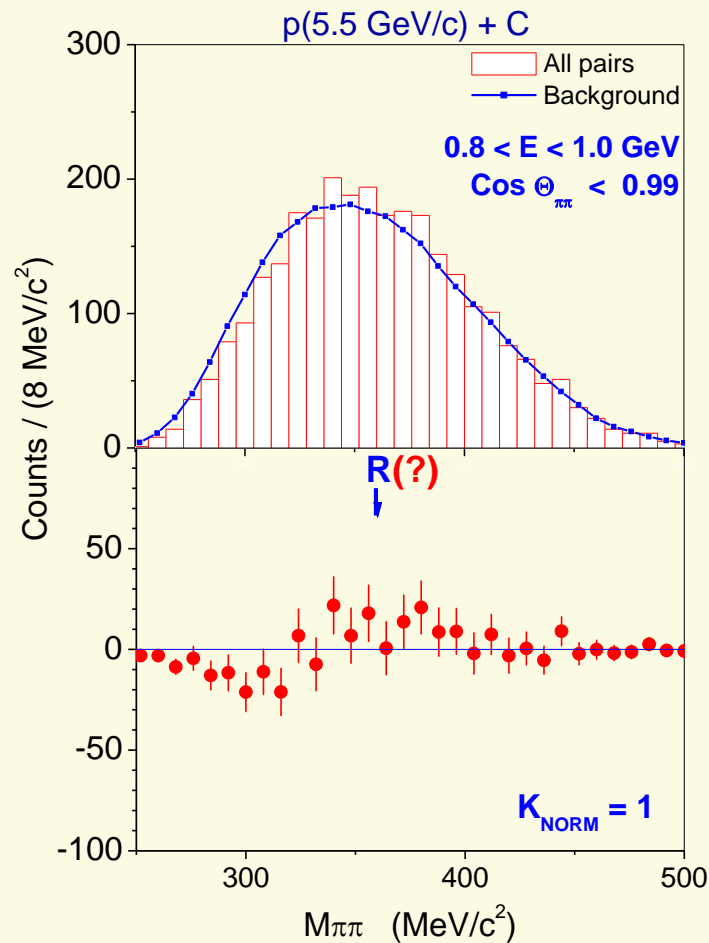

Preliminary

Distribution of the opening angle of $\pi^0\pi^0$ pairs

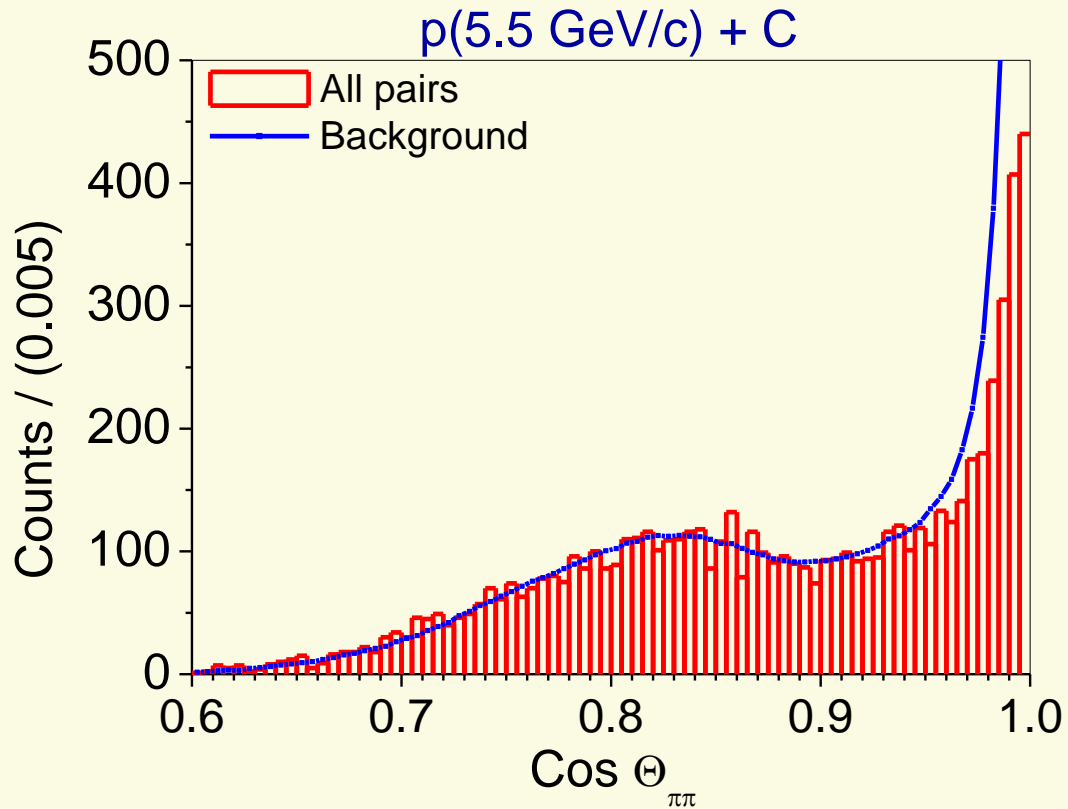

Preliminary

The invariant mass spectra of two π^0

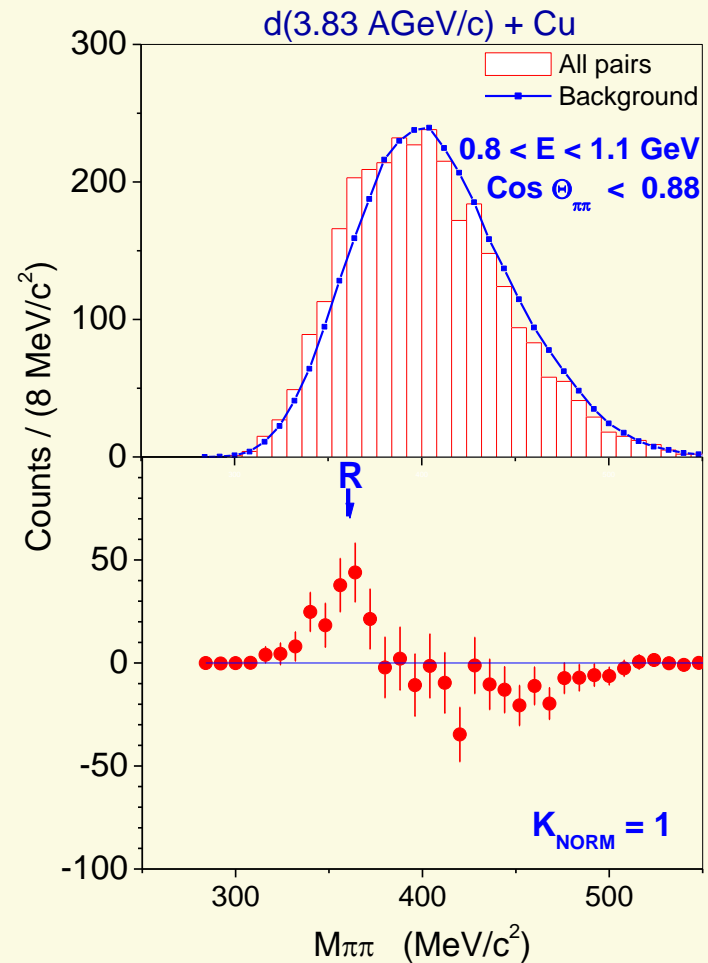
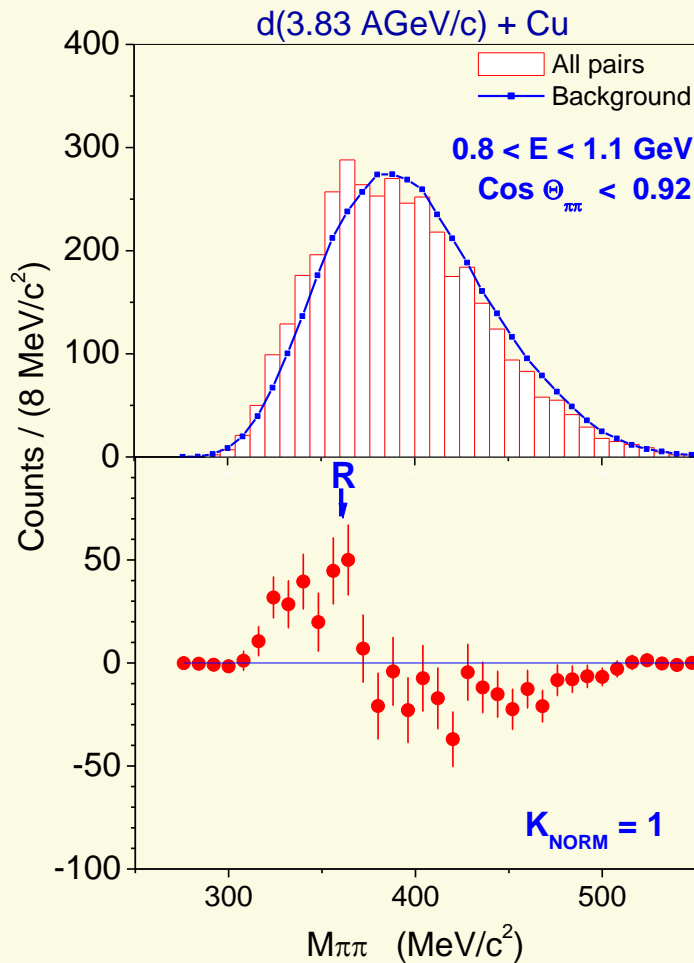

Concluding remarks

1. Following a experiment at the JINR Nuclotron the resonans-like enhancement was observed in two-gamma spectrum in dC -interactions (2.75 GeV/c per nucleon). Estimates of its characteristics are:
 $M_{\gamma\gamma} = 360 \pm 7 \pm 9 \text{ MeV}$, $\Gamma = 64 \pm 18 \text{ MeV}$.
2. A structure like this was not observed in the $M_{\gamma\gamma}$ spectrum from pC (5.5 GeV/c) interactions while the η meson was clearly seen in both the cases.
3. The data obtained in the $d+C$ reaction is confirmed by $d+Cu$ experiment at 3.83 GeV/c per nucleon.

Concluding remarks

4. To understand the nature of the observed effect were attempted some dynamic mechanisms:
 - production of the hypothetic R resonance in $\pi\pi$ interactions during the evolution of the nuclear collision;
 - formation of the R resonance with participation of photons from the Δ decay;
 - the $\pi^0\pi^0$ interaction effect in the $3\pi^0$ channel of the η decay;
 - a particular decoupled dibaryon mechanism.

Concluding remarks, outlook

5. The dibaryon mechanism is discussing as a possible explanation of observed enhancement. In this way it can be considered as σ -meson.
6. There are strong indications that the resonance exists in the $\pi^0\pi^0$ system. The data are now under the analysis.
7. From the experimental side: new experiments are required to be carried out under conditions appropriate for registration of pairs of two photons within the invariant mass interval of 300-400 MeV. Some scanning in the beam energy and mass will clarify the possible resonance structure of this effect. As the first experiment is required:
 $pA \rightarrow \gamma\gamma + X$ at $T_p \sim 2 - 5$ GeV.

Thank you for attention!

Planned experiments on external beams of the NUCLOTRON-M

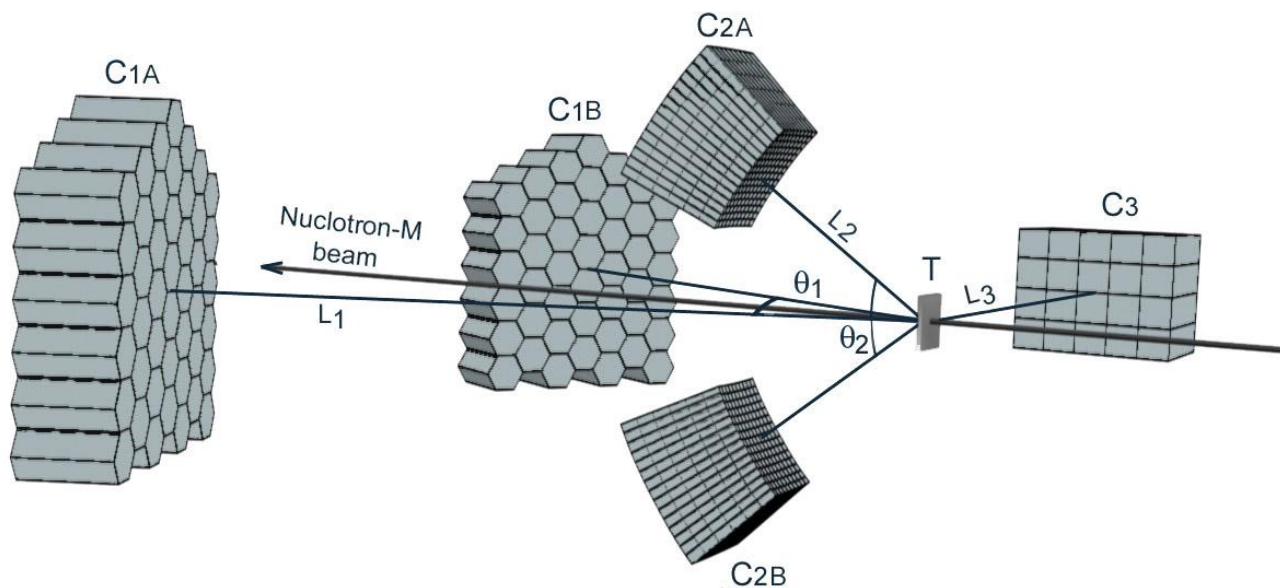

Invariant mass distributions of $\gamma\gamma$ pairs in two different runs of measurement under condition $E_\gamma \geq 50$ MeV: with the empty target (dashed histogram) and with the internal carbon target (solid histogram) in the reaction $dC \rightarrow \gamma + \gamma + X$ at 2.75 GeV/c per nucleon.

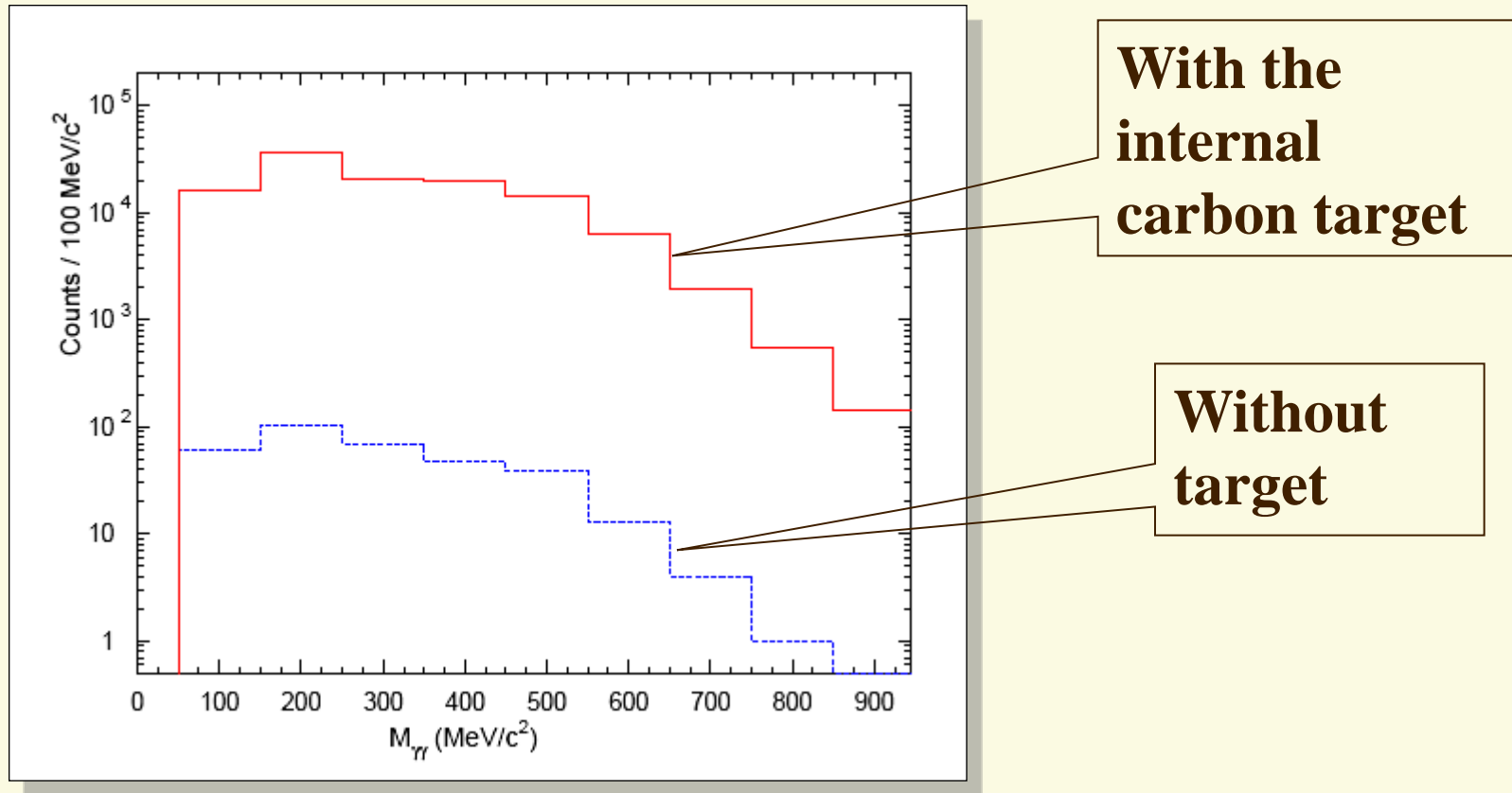

Charged particles contribution

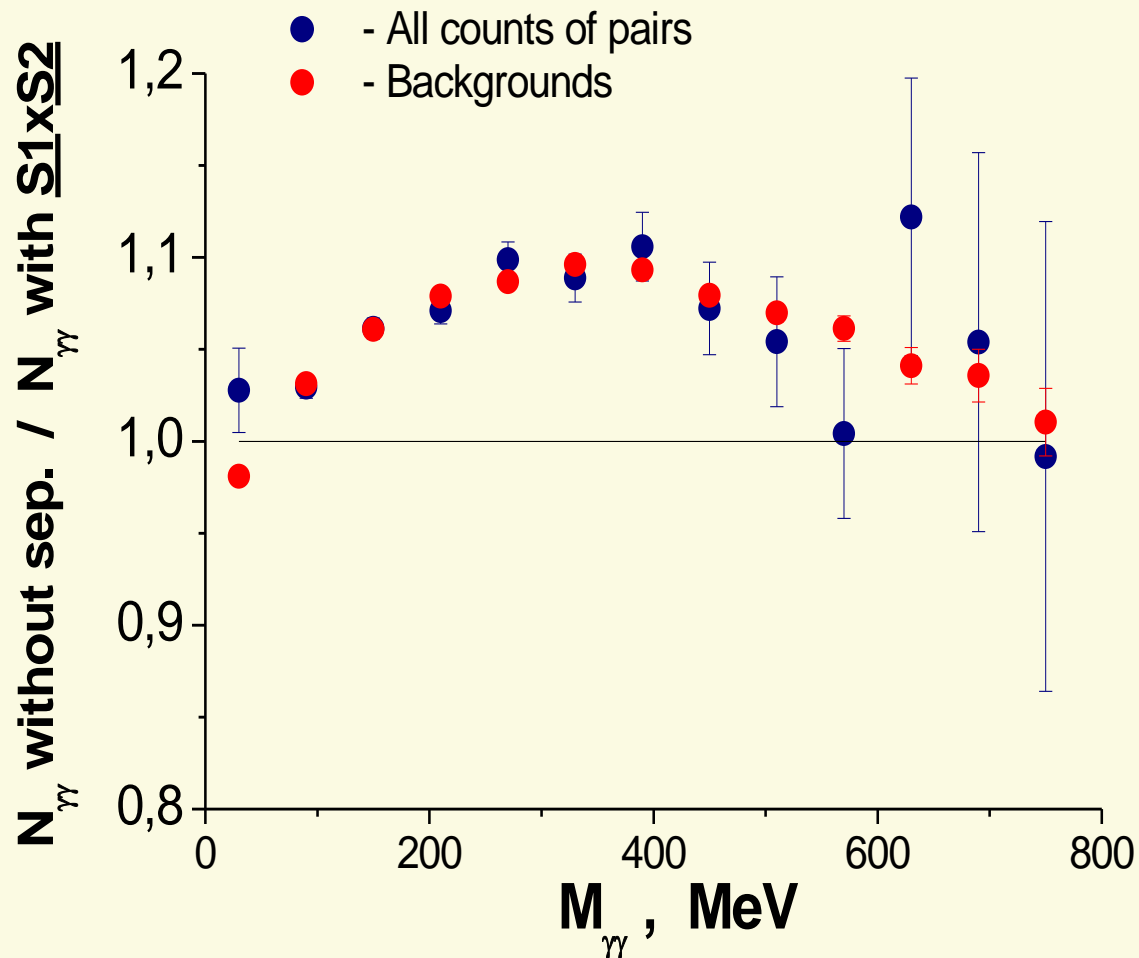

Charged particles contribution after background subtraction

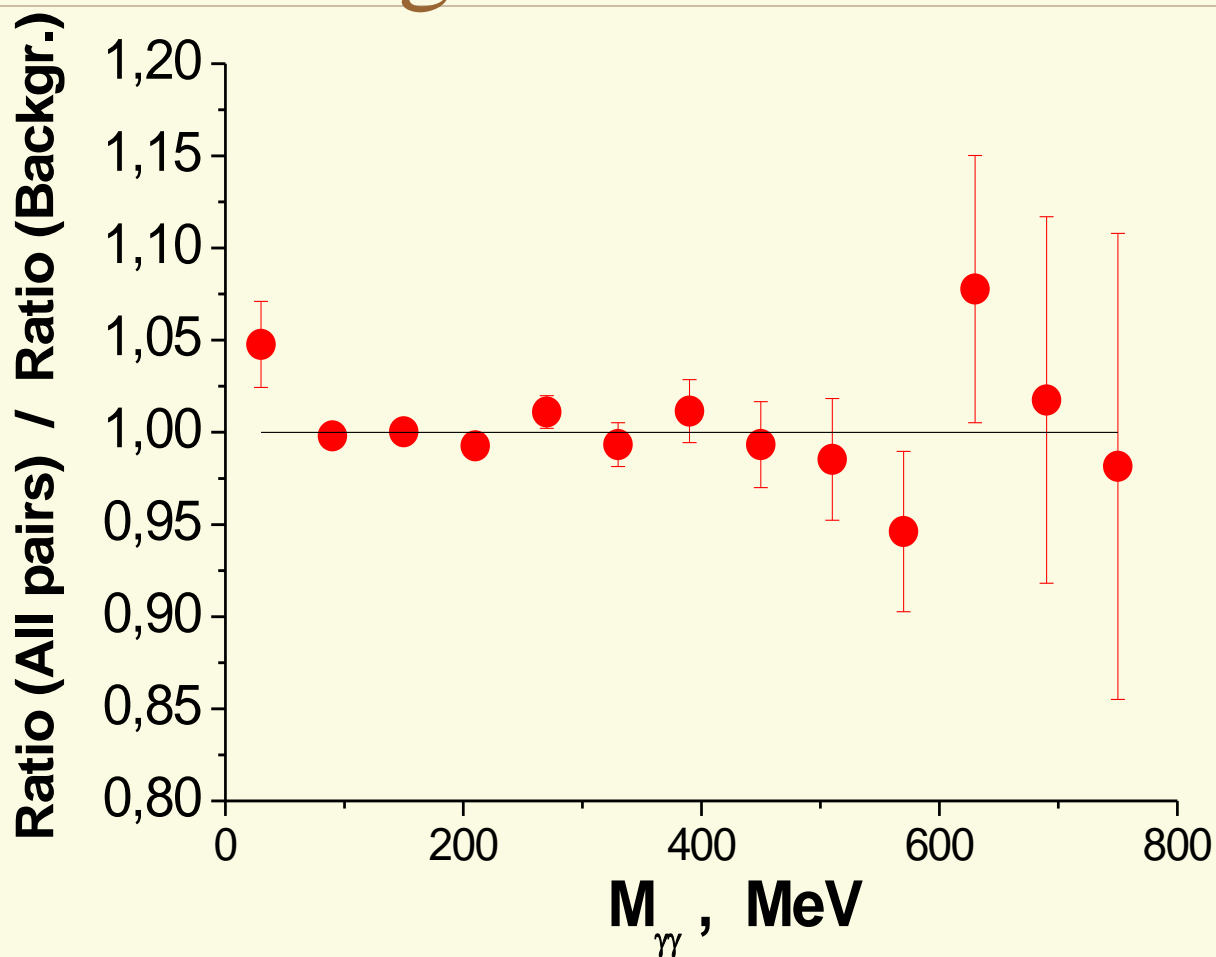

Invariant mass distributions of $\gamma\gamma$ pairs satisfying the criteria (1) – (2) after background subtraction in the reaction $dC = \gamma + \gamma + X$ at 2.75 GeV/c per nucleon for two different beam intensities: 503 events/cycle (a) and 85 events/cycle.

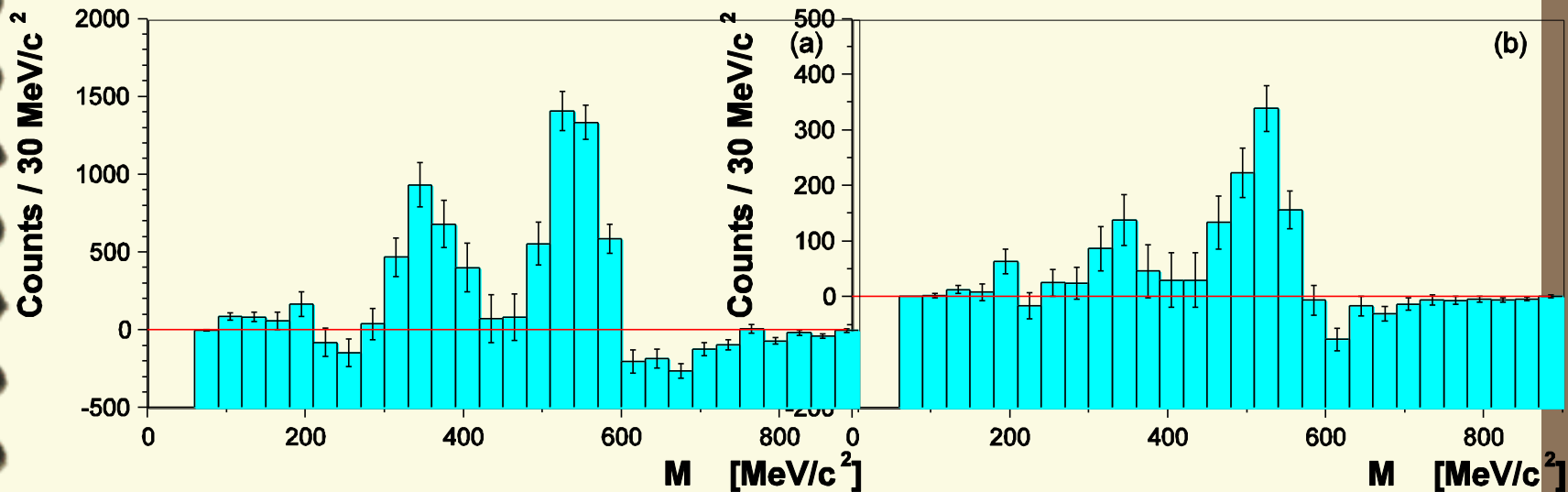

The invariant mass distributions of two photons for the opening angles $0.55 < \cos(\Theta_{\gamma\gamma}) < 0.65$ (left) and $0.65 < \cos(\Theta_{\gamma\gamma}) < 0.75$ (right) under the selection criteria (1) – (2).

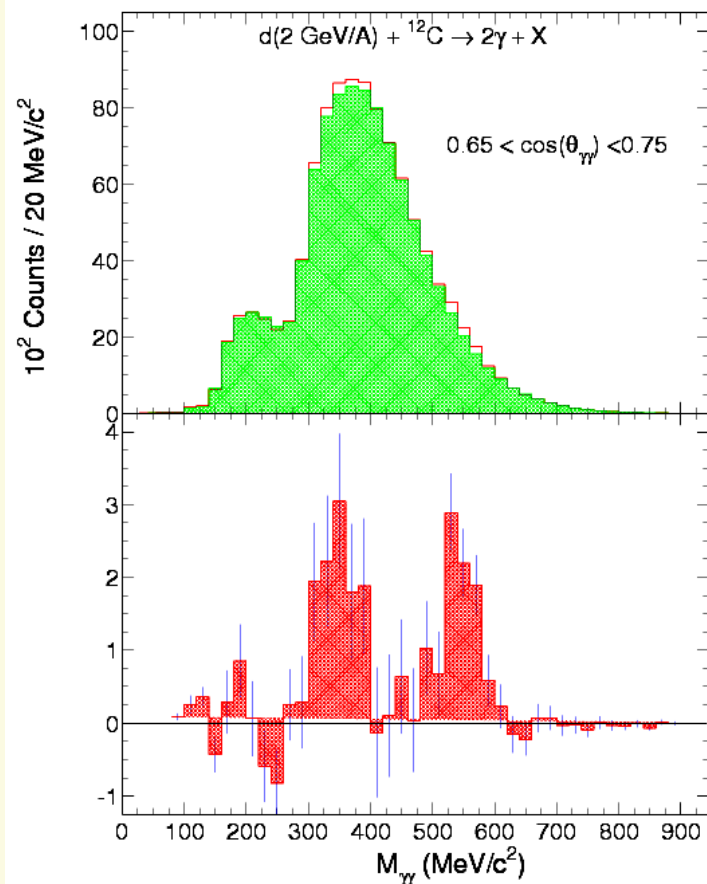
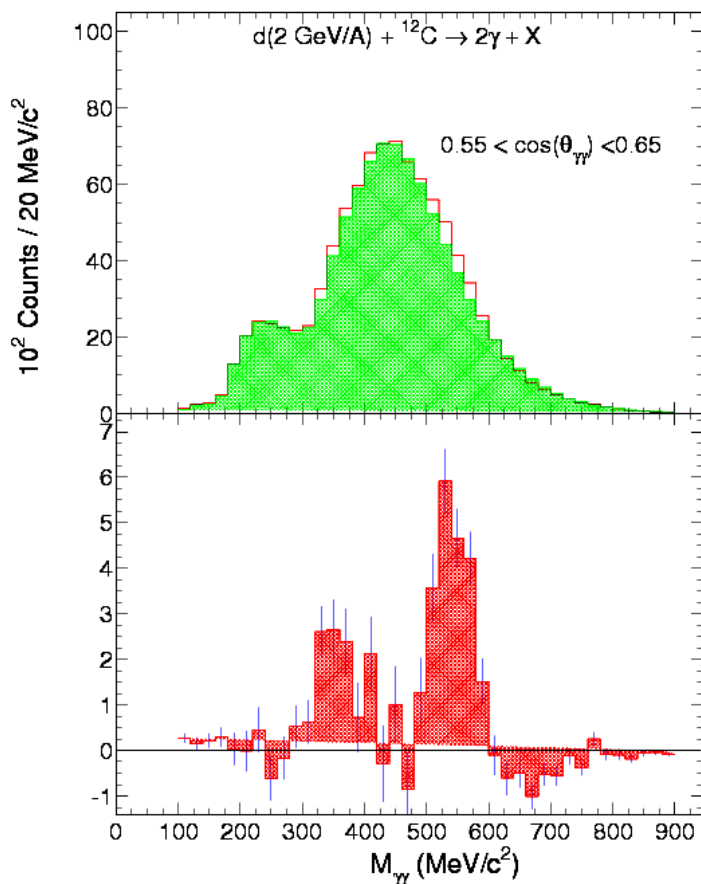

The invariant mass spectra of $\gamma\gamma$ pairs for the energy selection $E_\gamma > 400$ MeV under the selection criteria (1) - (2), $K_{\text{norm}} = 0.973$.

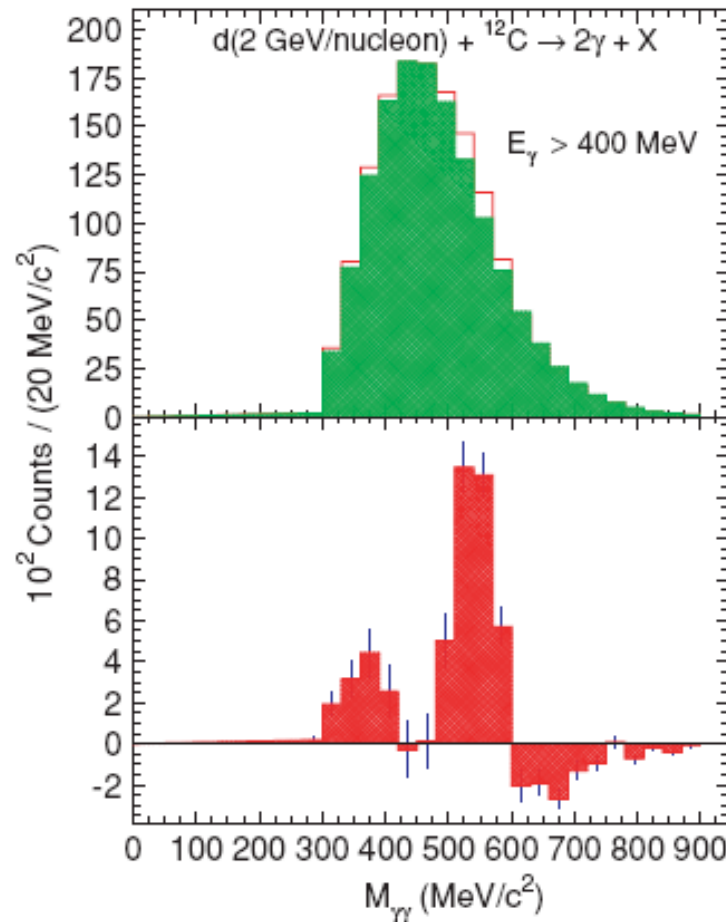

The invariant mass distributions of $\gamma\gamma$ pairs from the dC reaction under the criteria: $E_{\gamma 1} / E_{\gamma 2} > 0.5$ (left) and $E_{\gamma 1} / E_{\gamma 2} < 0.5$ (right).

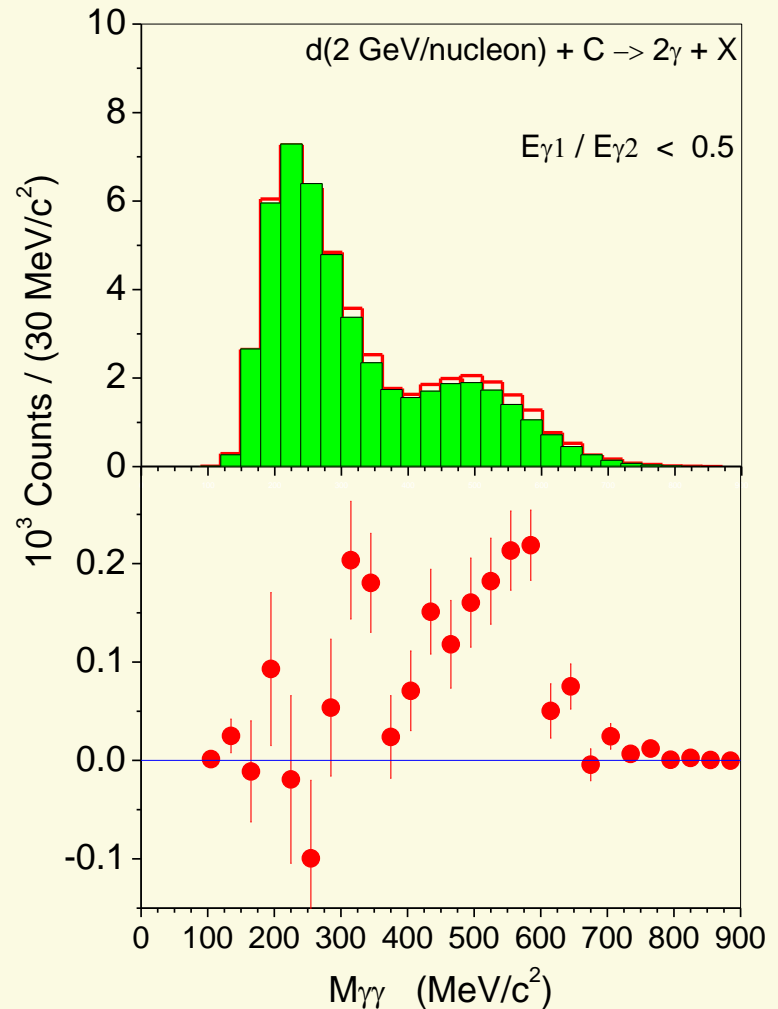
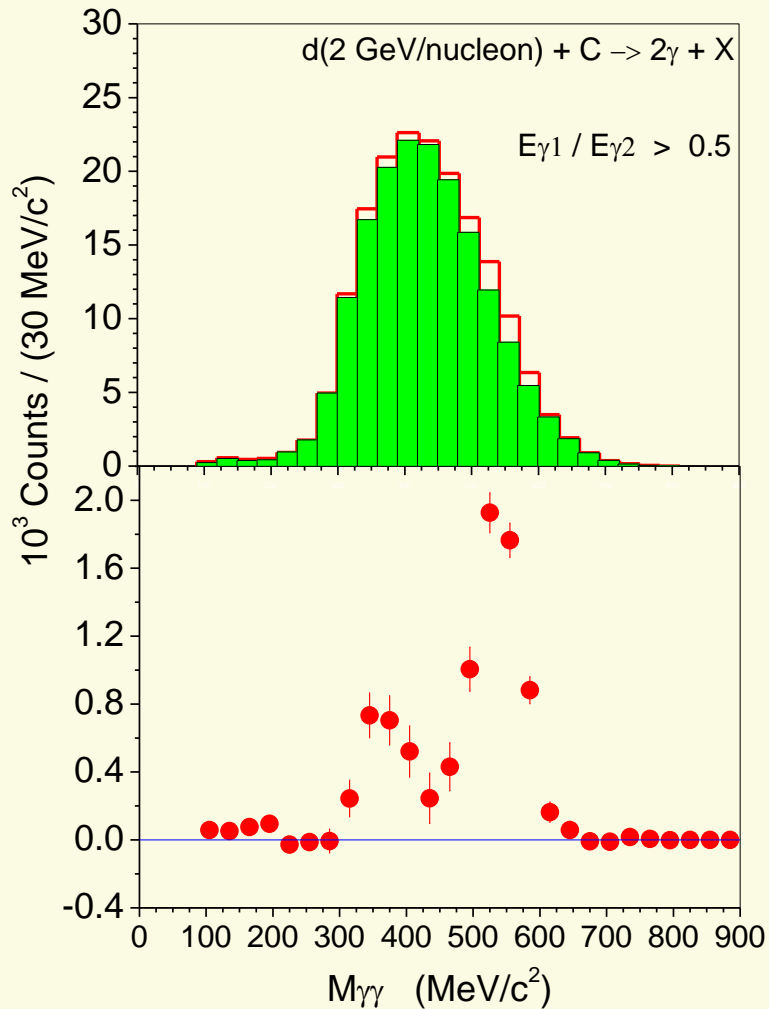

The invariant mass distributions of $\gamma\gamma$ pairs from the pC (left) and dC (right) reactions after background subtraction under the criterion: $N_\gamma (E_\gamma > 300 \text{ MeV}) = 3$

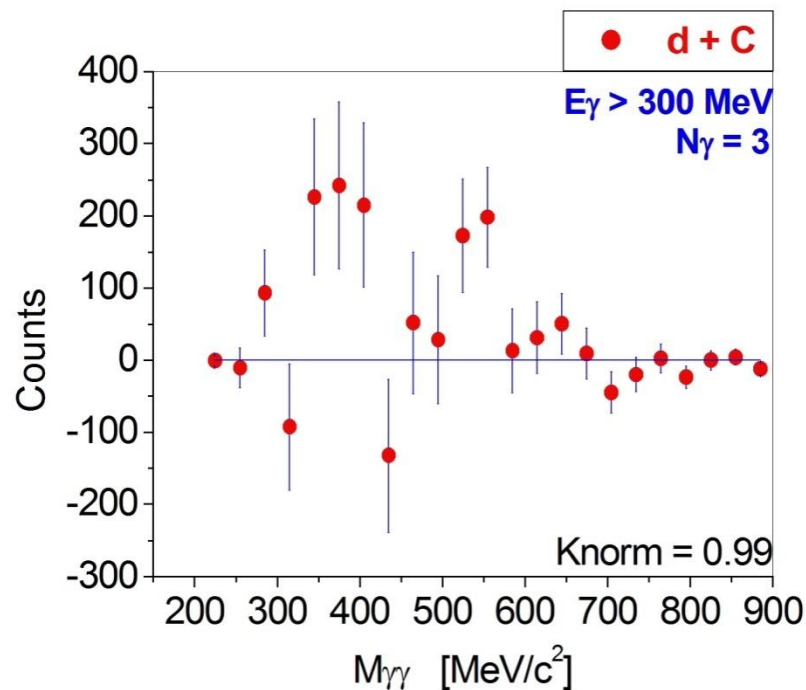
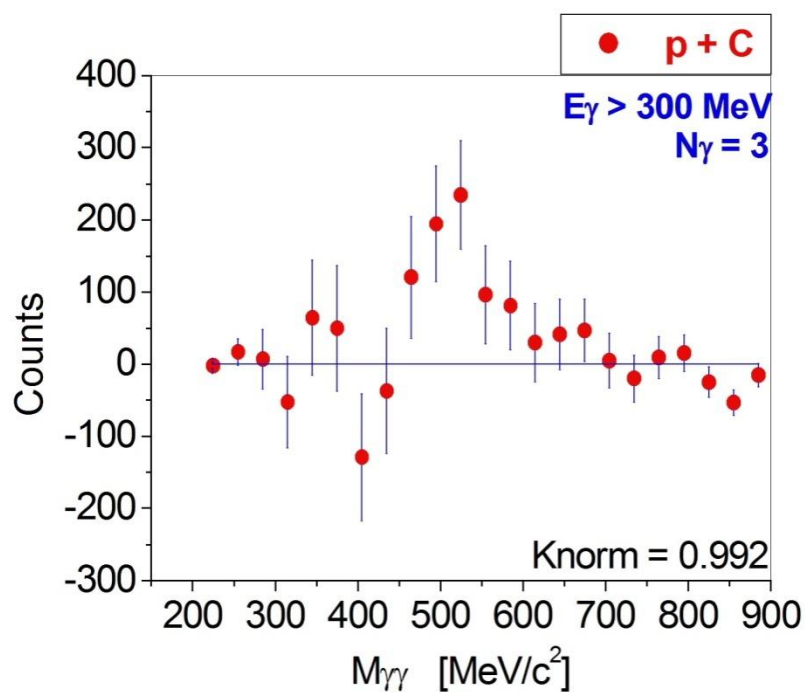

Distribution of the opening angle of $\gamma\gamma$ pairs in dC collisions for the two selections of $(E_{1\gamma} + E_{2\gamma})$.

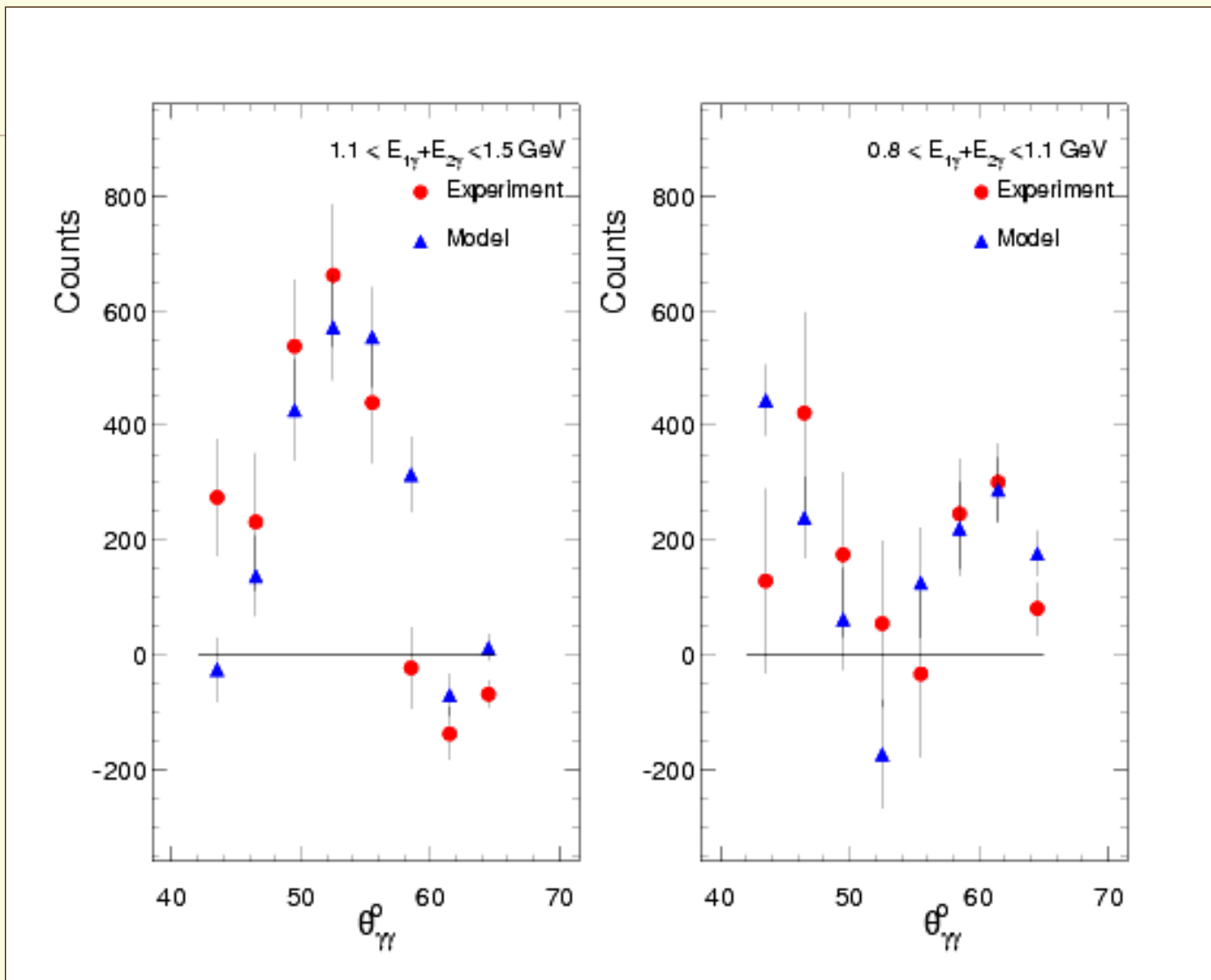

$N_{\gamma}=3$

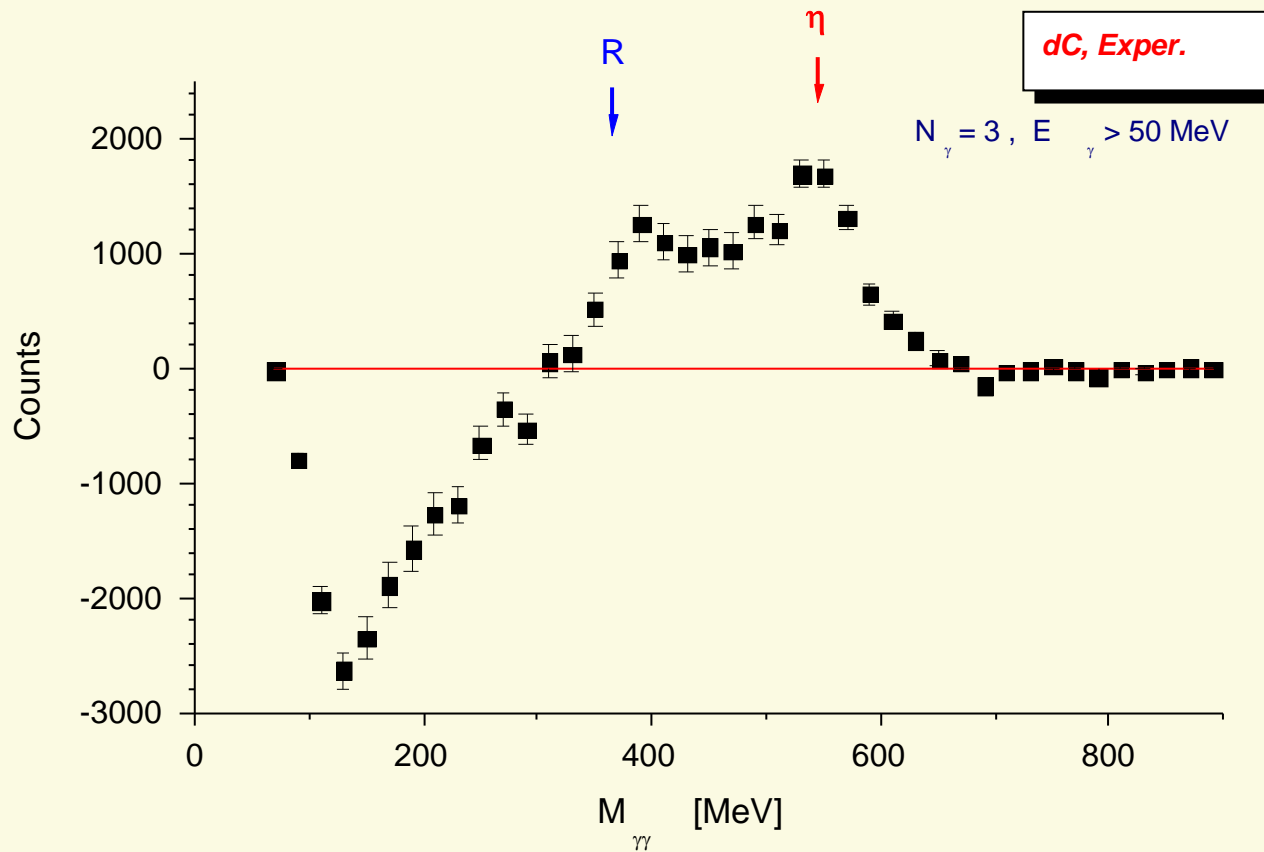

$N_{\gamma}=3$: 1 γ in the L.Arm, 2 γ in the R.Arm +
 2 γ in the L.Arm, 1 γ in the R.Arm

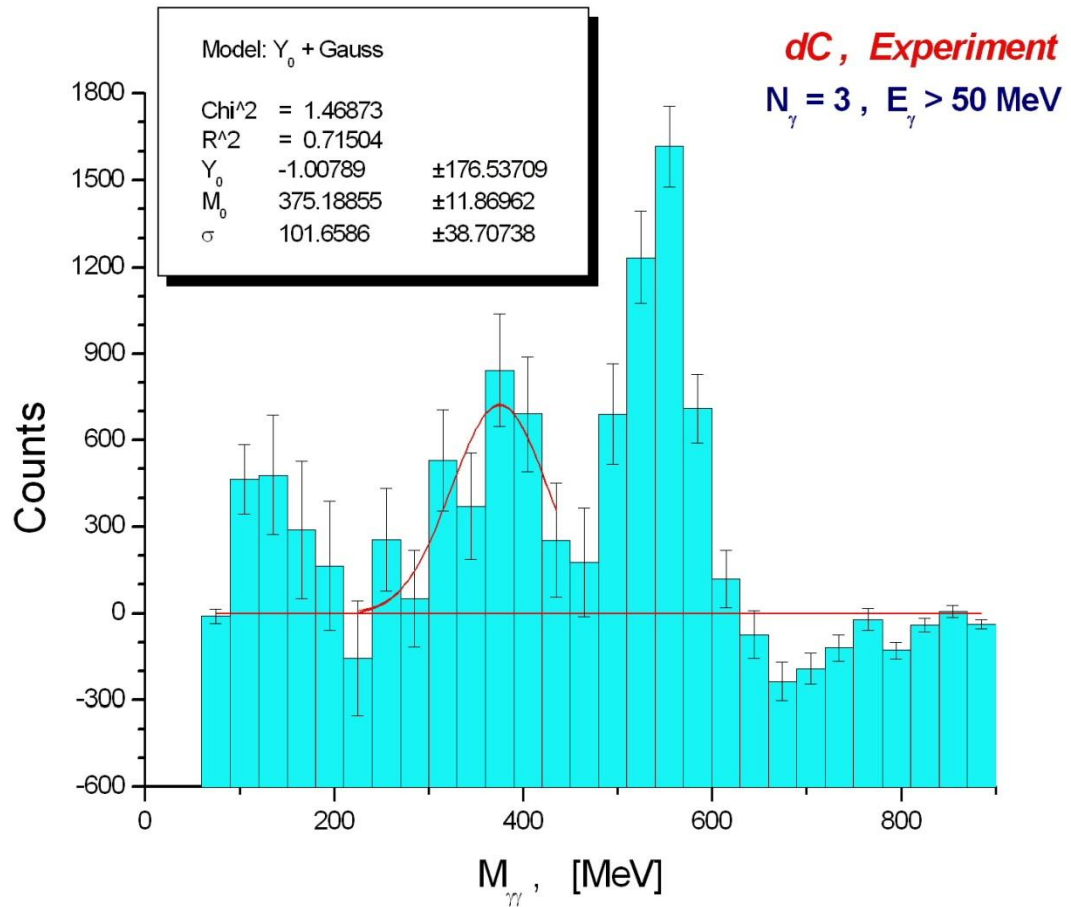

The invariant mass distribution of $\gamma\gamma$ pairs and the biparametric distribution of the GW of the 8-th order for dC (left) and pC (right) interactions. The distribution is obtained with an additional condition for photon energies $E_{\gamma 1}/E_{\gamma 2} > 0.8$ and binning in 2MeV.

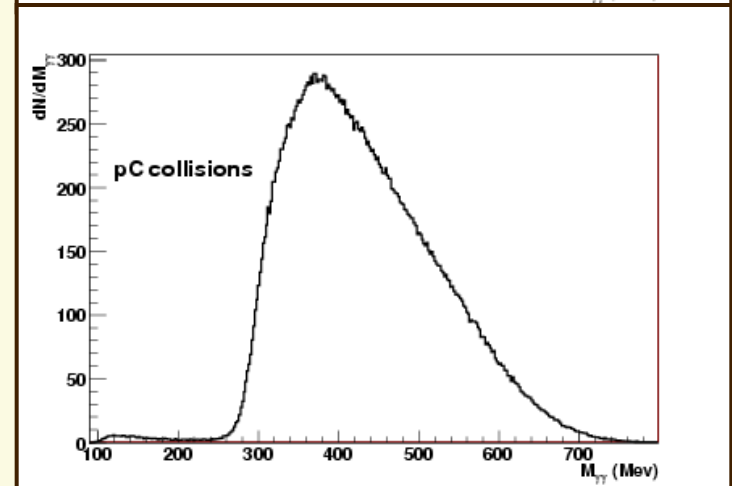
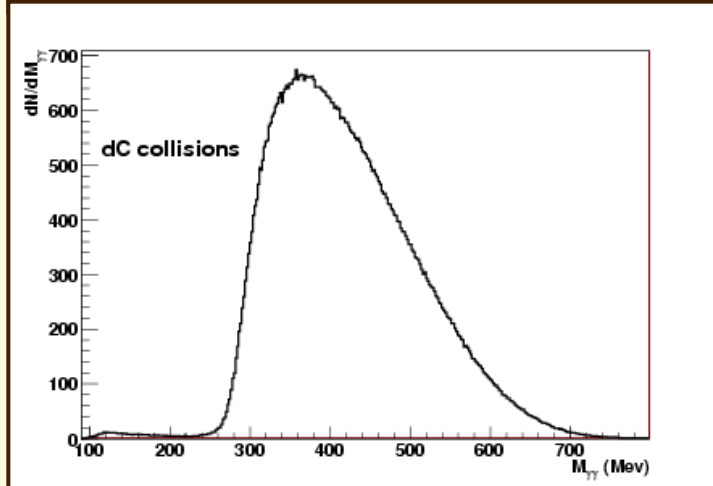
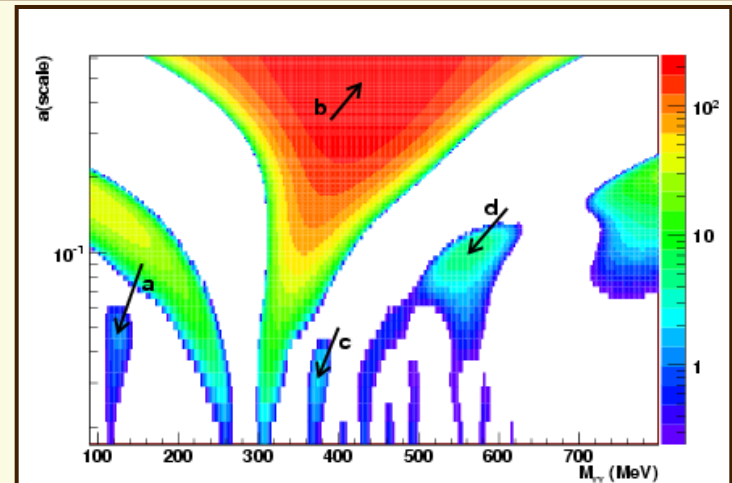
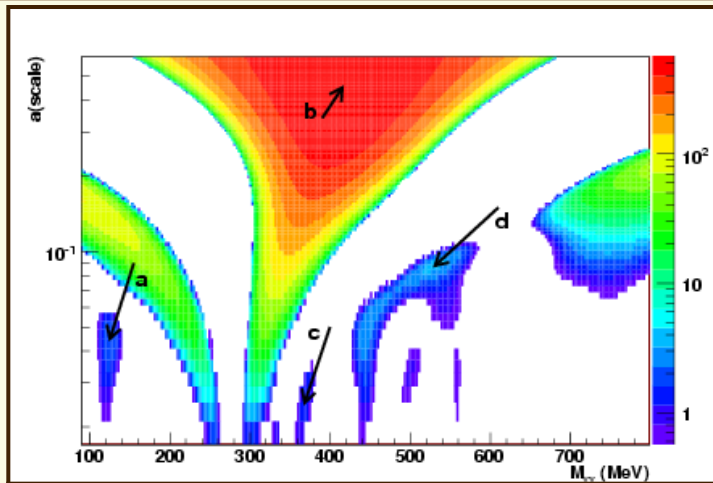

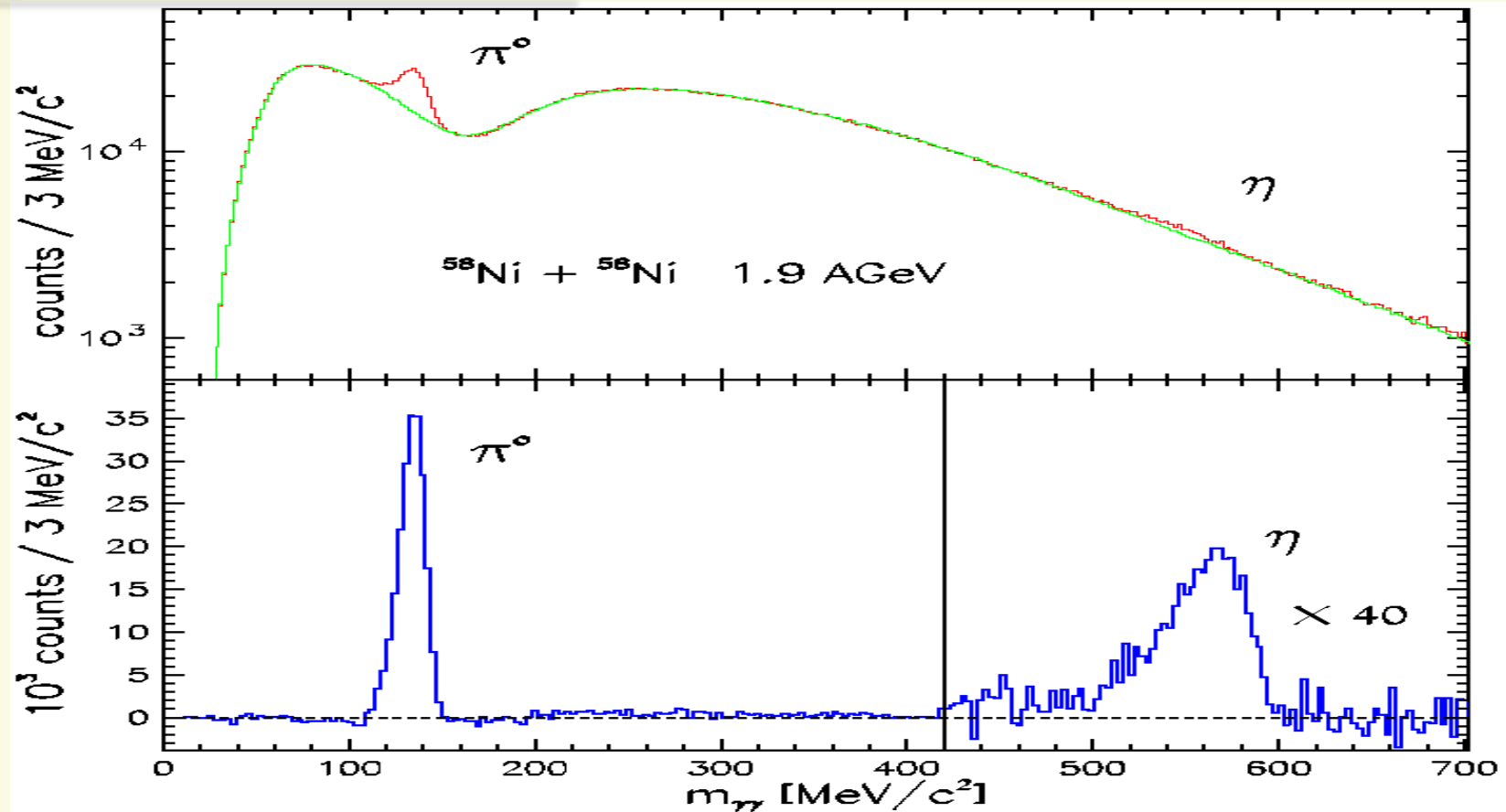

A.Taranenko et.al, Czech.J.Phys. 50S4 (2000) 139, nucl-ex/9910002.

Results of the invariant-mass analysis of photon pairs (TAPS). The upper frame shows the invariant-mass spectrum which corresponds to the η trigger in the experiment $^{58}\text{Ni} + ^{58}\text{Ni}$ at 1.9 AGeV. The combinatorial background (dotted line) was determined by event mixing. The lower frame shows the invariant-mass distribution after background subtraction and demonstrates the quality of the background determination.

R. Averbeck *et al.*
 (TAPS Collaboration),
 Z. Phys. A **359**, 65 (1997).

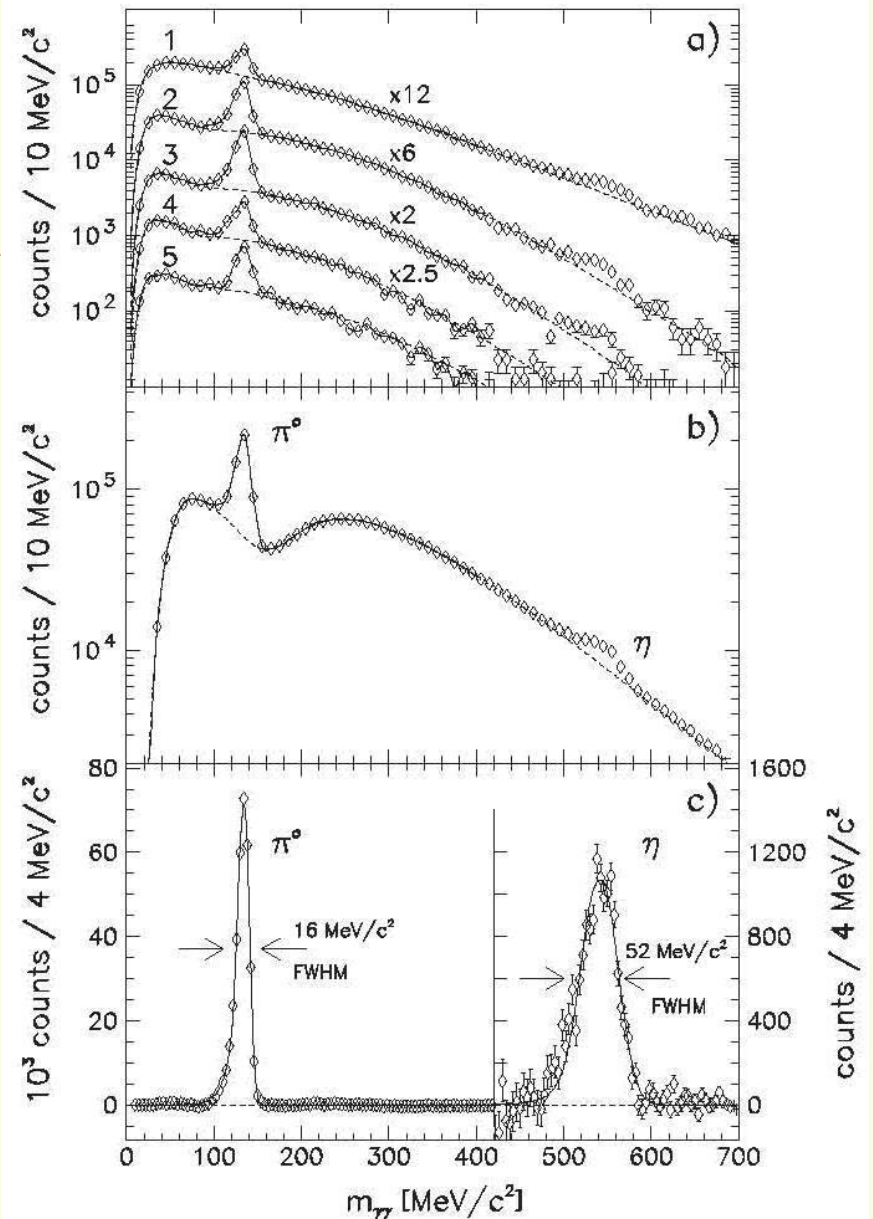

Comparison with experiments on the “TAPS”

1. Z.Phys.A359, 65(1997): C+C reaction, 2.0A GeV

	TAPS	PHOTON-2
Opening angles	65°-102°	42°-66°
η energies (GeV)	> 0.70	> 1.01
Mean values	0.85	1.21
O.R. energies	> 0.457	> 0.652
Mean values	0.552	0.782
Total cr. sect. (b)	2.021	0.612
Arm's area (m ²)	0.578	0.424
Arm's solid angle (sr)	0.257	0.047
En.res. σ/E (m.v.,%)	3.0	6.1
Sig./B. in 300-420:	~ 0.0014 ^a (<0.004)	0.027

^a Sig. ~ $\sqrt{6} \cdot 10^5$

Necessary statistics for same observation in the experiment
on TAPS

(Z.Phys.A359, 65(1997): C+C reaction, 2.0A GeV)

$$\sim 3 \cdot 10^{12} \cdot (\Delta\Omega_{\text{PHOTON}} / \Delta\Omega_{\text{TAPS}})^2 \cdot (\Delta M_{\text{PHOTON}} / \Delta M_{\text{TAPS}})^2 \cdot [(S/B)_{\text{PHOTON}} / (S/B)_{\text{TAPS}}]^2$$

$$\underline{S/B=0.0014}$$

$$\sim 3 \cdot 10^{12} \cdot (0.047 / 0.257)^2 \cdot (3.0 / 6.1)^2 \cdot (0.027 / 0.0014)^2$$

$$= 9 \cdot 10^{12} \text{ interactions,}$$

$$\underline{S/B < 0.004 :}$$

$$> 1.1 \cdot 10^{12} \text{ interactions.}$$

$$N_{\text{cycle}} > (1.1 \cdot 10^{12}) / (5 \cdot 10^6 \cdot \omega) =$$

$$= 4\,500\,000 \text{ accelerator cycles,}$$

$$\omega = \rho_X \cdot (N_A / A) \cdot \sigma(\text{CC}) = 0.049, \quad \rho_X = 0.487 \text{ g/cm}^2$$

For indication (+3 st.err.) : > 550 000 acceler. cycles

WA80 Collaboration, Phys.Lett. B361 (1995) 14, hep-ex/9507009.

Invariant mass distributions for the 200 AGeV/c (SPS) S+Au data in the π^0 (a) and η (b) mass range after background subtraction. The signal to the background ratio is $5.7 \cdot 10^{-2}$ and $7 \cdot 10^{-4}$.

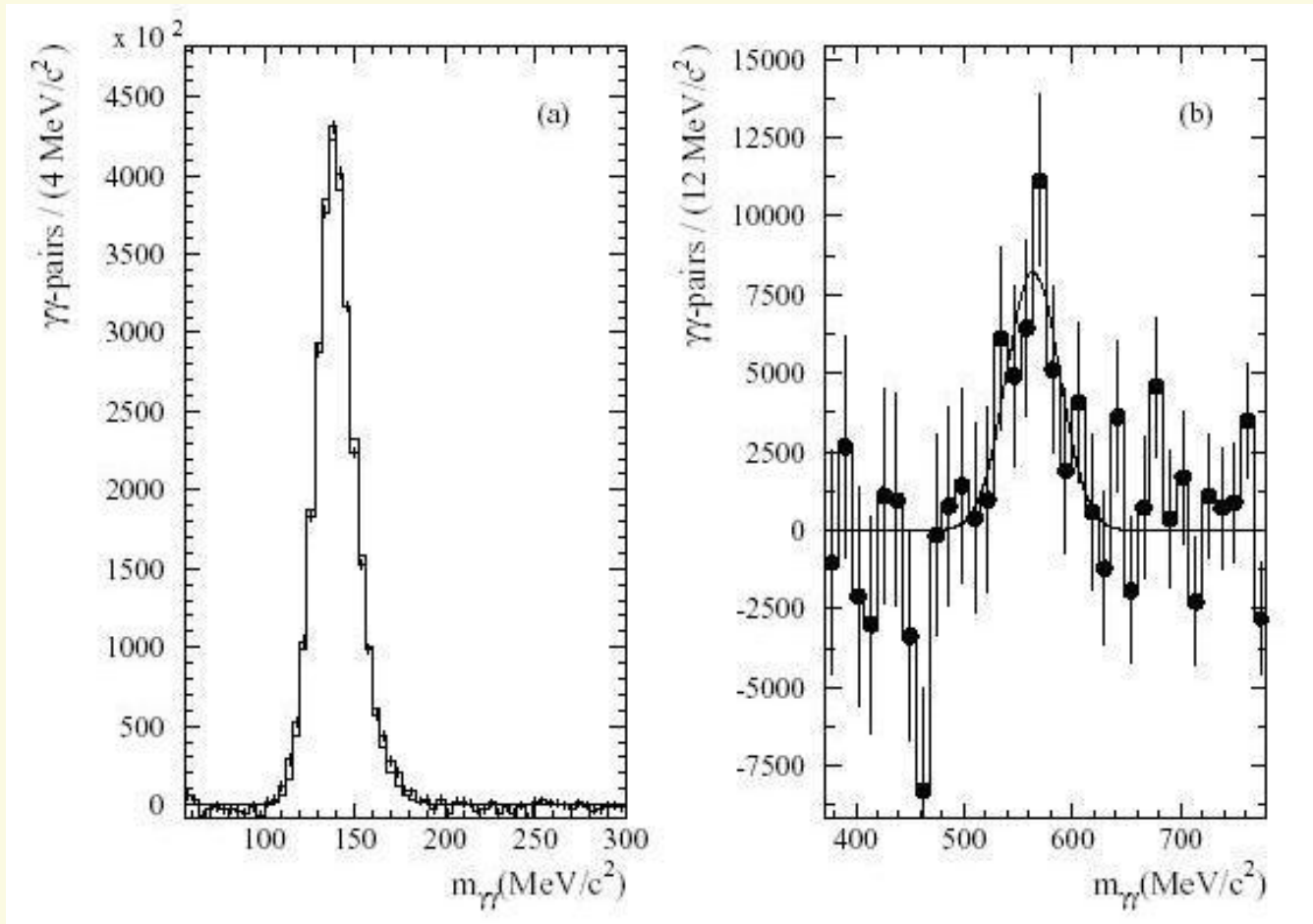

- WASA-CELSIUS (Int. J. of Mod. Phys. A, 2005, v.20, p.554):
- (a) M spectrum after kinematic fit. The dotted histogram in shows background expected from misidentified $\pi^0\pi^0$ events.
 - (b) The same as (a), but for $T_p = 1.2$ GeV.

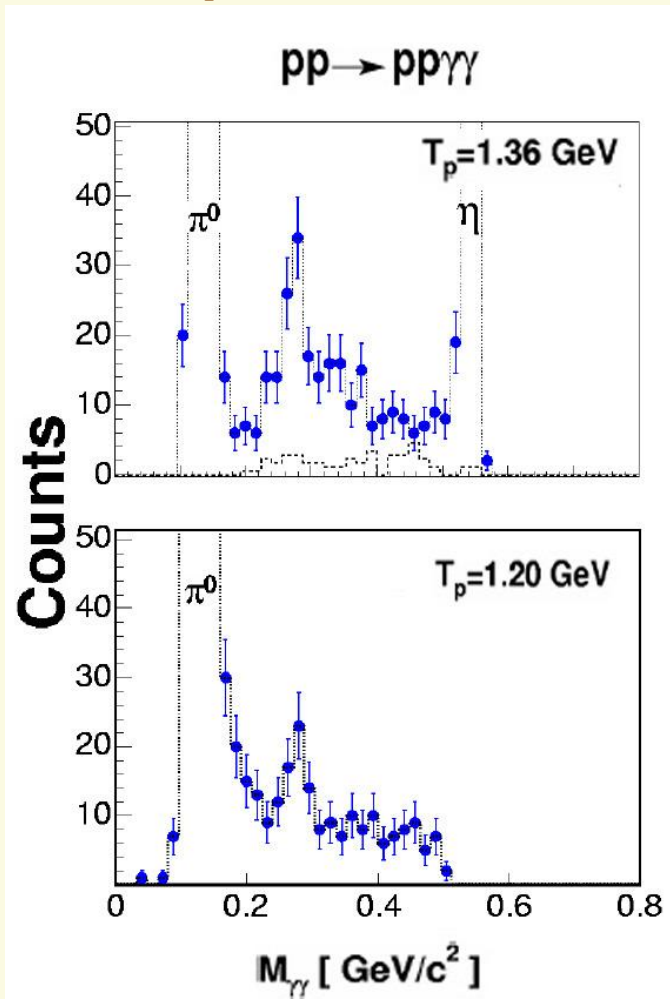

J.Banaigs, J.Berger et al. ABC and DEF effects// Nucl.Phys. **B67**, (1973),1.

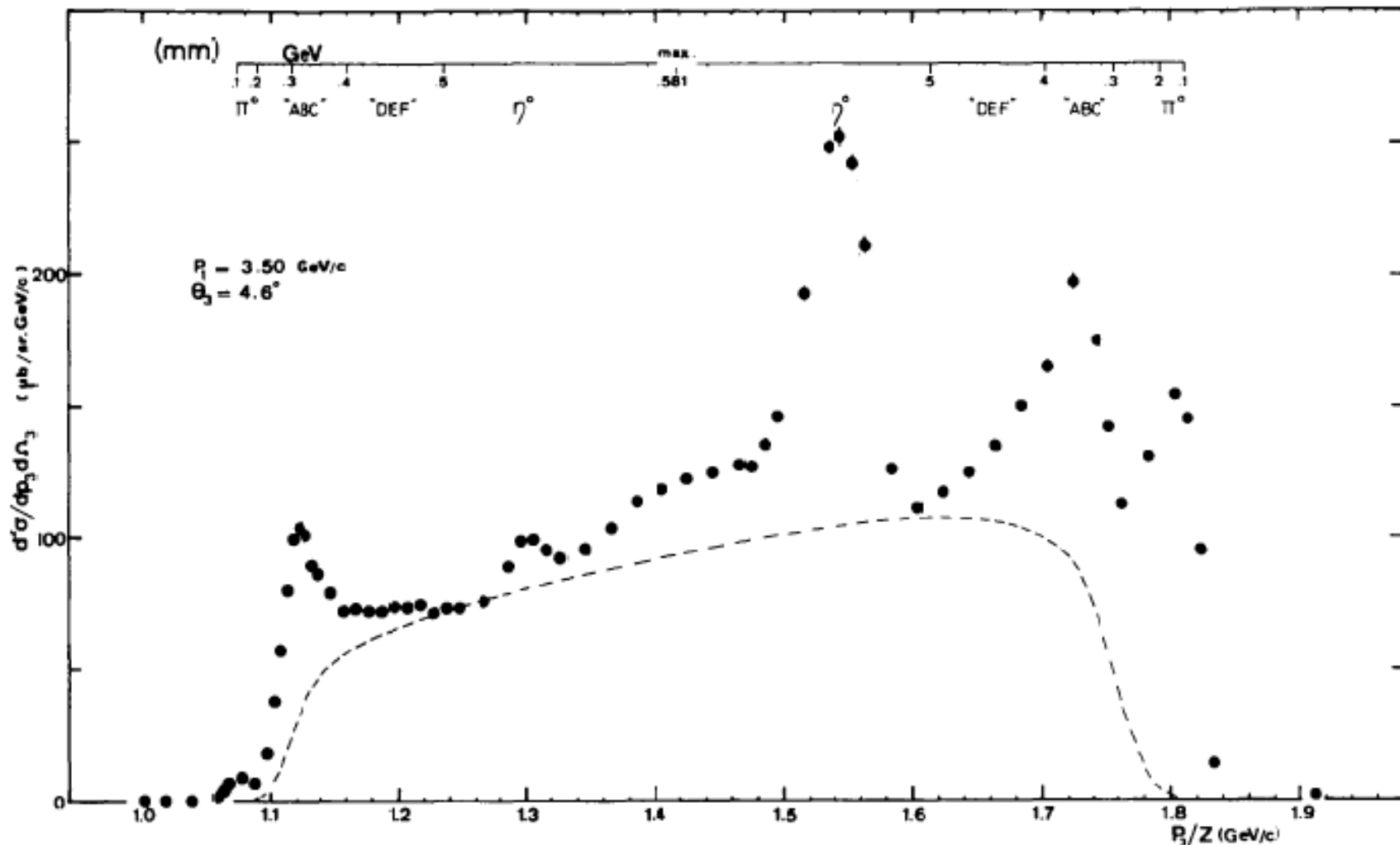

Fig. 10. Momentum spectrum of the He^3 from the reaction $d + p \rightarrow He^3 + (\pi\pi)^0$ at $p_1 = 3.50 \text{ GeV}/c$ and $\theta_3 = 4.6^\circ$.

L. N. Andronenko, B.L. Gorshkov, G.E. Solyakin
Preprint of PINP 2792, Gatchina - 2009.

... Thus in attention has been accepted as the basic decay $\sigma \rightarrow \pi + \pi$, and till now remaining hypothetical branch $\sigma \rightarrow \gamma + \gamma$.

... Three differing branches of ... splittings of nuclei of tungsten by protons with energy of 1 GeV testify to presence of three discrete values of energy of excitation of the residual nucleus (*thus the energy of excitation reserved in a residual nucleus, can be in an interval of 325-343 MeV*). This experimental fact allows to conclude that there is a possibility of absorption of both particles of disintegration in a nucleus, and also possibility of absorption of one and emission another and, at last, possibility of emission of both particles of disintegration. Such scheme well corresponds to the mechanism of connection of σ -meson formation with three versions of nuclear splittings.

Invariant mass distributions of $\gamma\gamma$ pairs without (upper panels) and with (bottom panels) the background subtraction for the reactions $d+C$ (left) and $d+Cu$ (right). **Minimal cuts: $E_\gamma \geq 50$ MeV.**

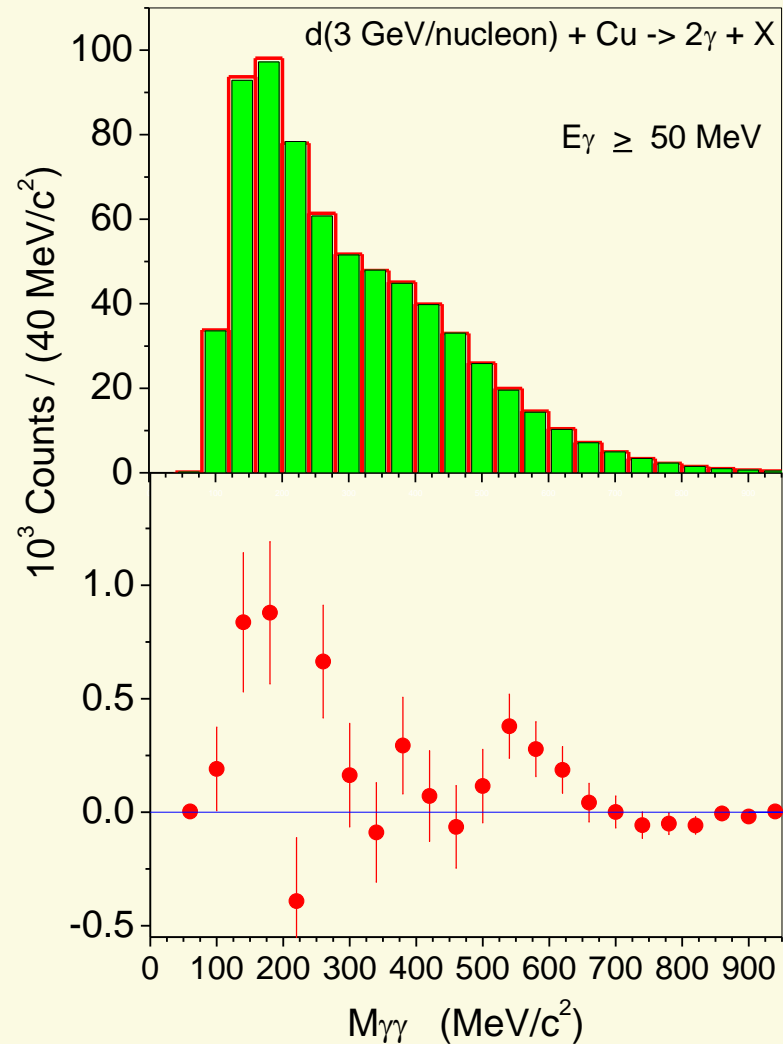
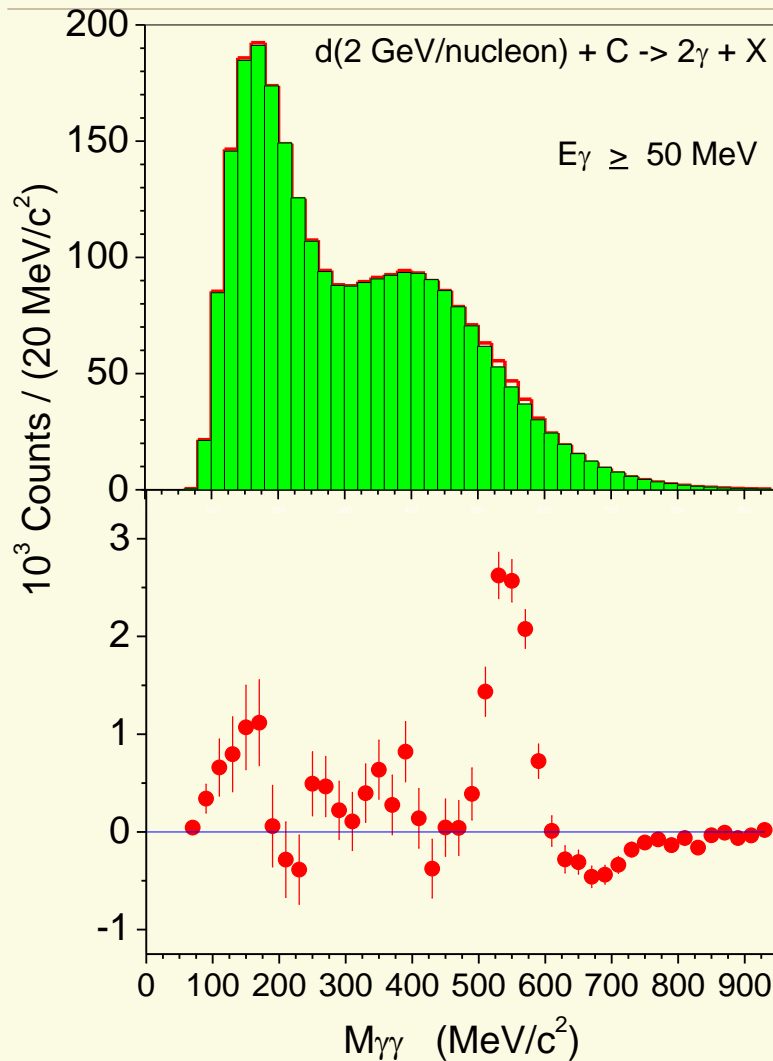

Photon energy spectra from $\gamma\gamma$ pairs in the invariant mass interval $M_{\gamma\gamma} = 0.32\text{-}0.4$ GeV. Experimental (circles) and Monte-Carlo simulation (triangles) points calculated with inclusion of the R resonance formation are given separately for every spectrometer arm. Distributions are normalized to the same total number of events.

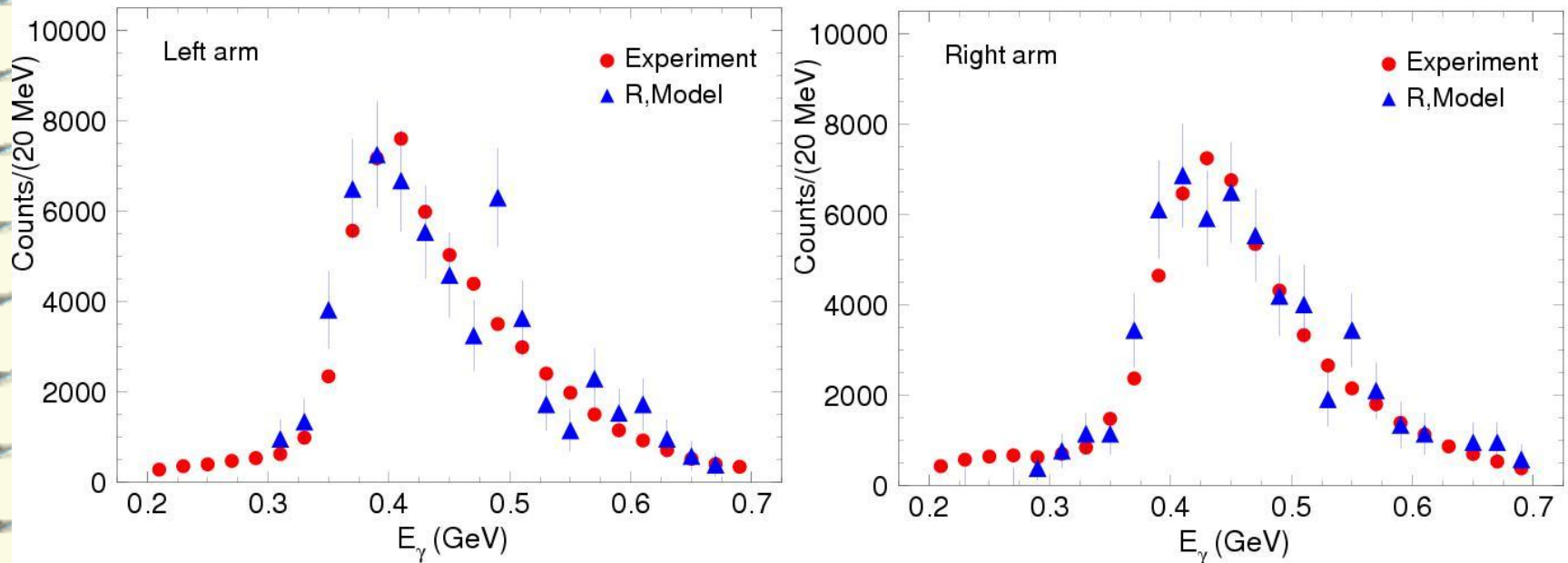

Invariant mass distributions of $\gamma\gamma$ pairs satisfying the criteria (1) – (2) after background subtraction in the reaction $dC = \gamma + \gamma + X$ at 2.75 GeV/c per nucleon. **Normalization of the background by the total number of pairs in the spectrum.**

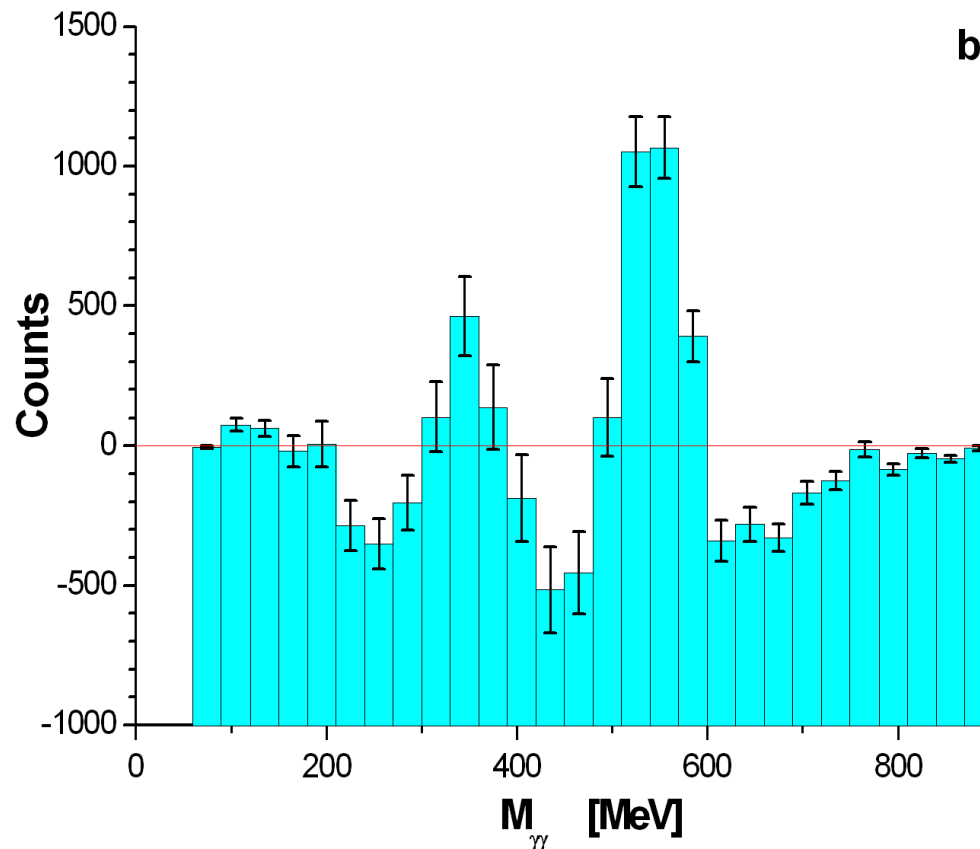

Результаты аппроксимации данных в интервале инвариантных масс 165-435 МэВ функцией **Брейта-Вигнера** (таблица слева, пунктирная кривая) и функцией **Гаусса** (таблица справа, сплошная кривая).

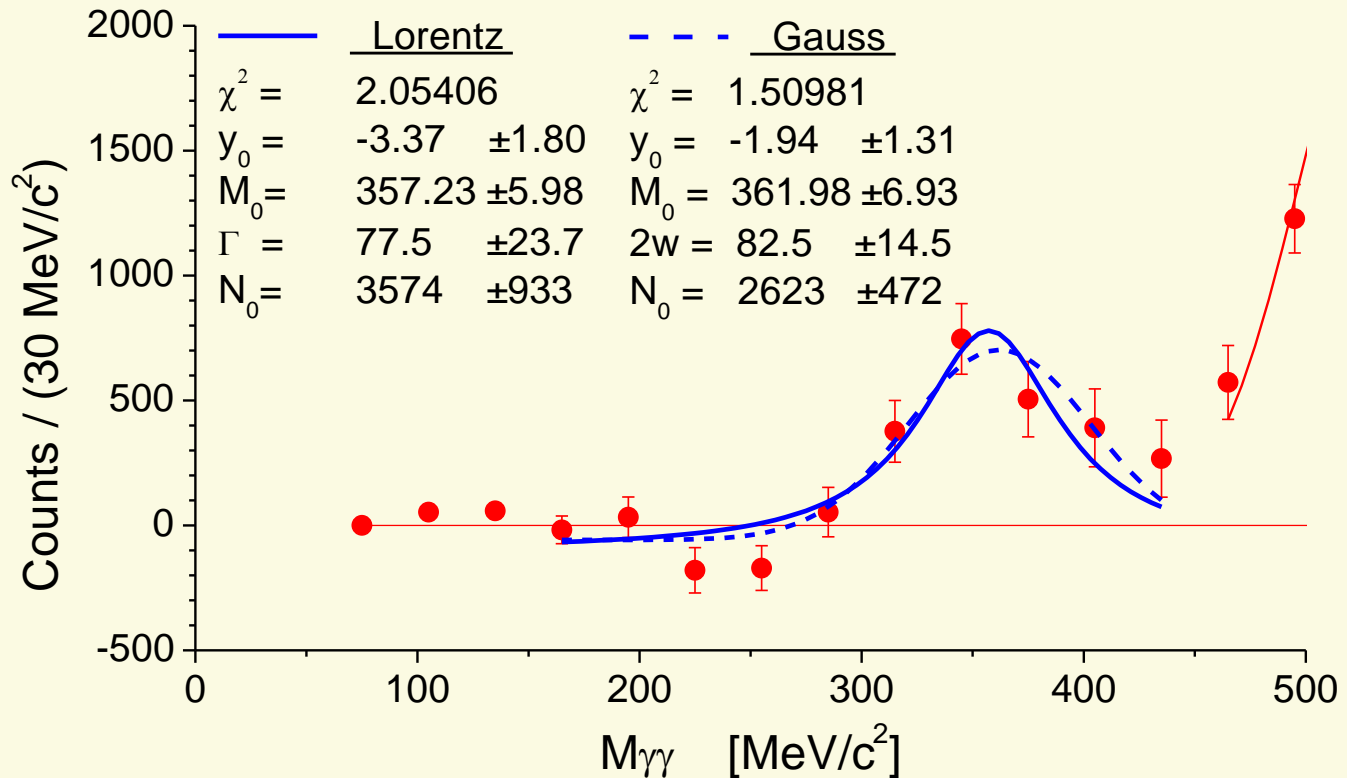

Определение сечений рождения

$$X) = [N (in mod) / (N (mod) / K(opt))],$$

$$N(d) = (1, K(empty) \sim 0.2.$$

The coefficient $K(opt) = 8.93$ takes into account the rotation of the modelled events in the plane.

$$\Rightarrow 1.31 \pm 0.11 + 1.24 - 0.89 \text{ mb.}$$

$$= (R)] / [N()] = (0.075 = 98 \pm 24 + 93 - 67 \mu b,$$

where the branching ratio is

$$-tot (R), \text{ and } Nmod(Nmod-tot ($$

are the detection and selection efficiency.

Invariant mass distributions of $\gamma\gamma$ pairs from the dC reaction. The top shaded histograms show the background contribution. The bottom histograms are invariant spectra after the background subtraction.

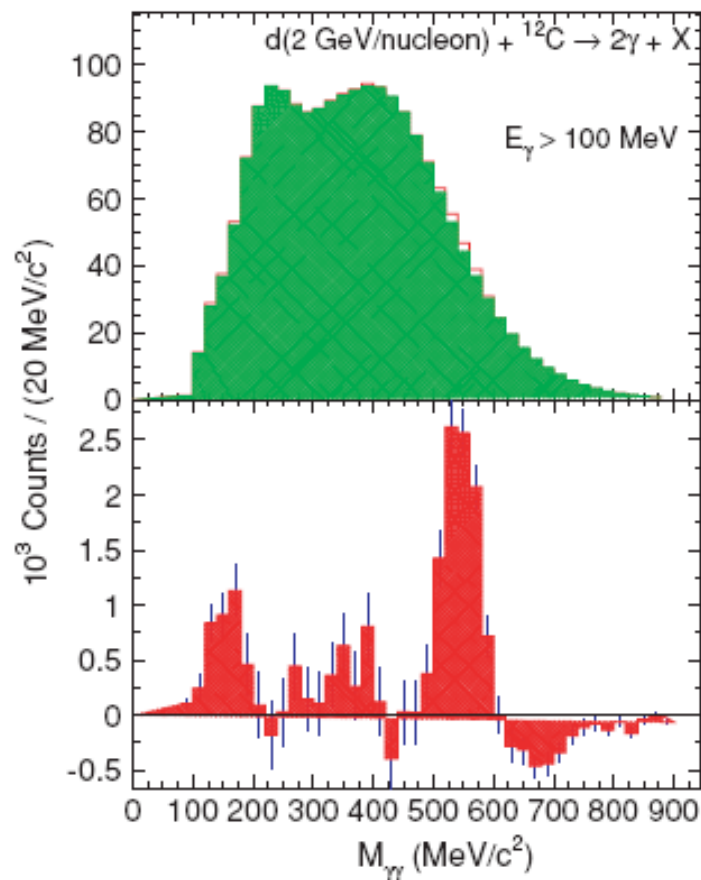
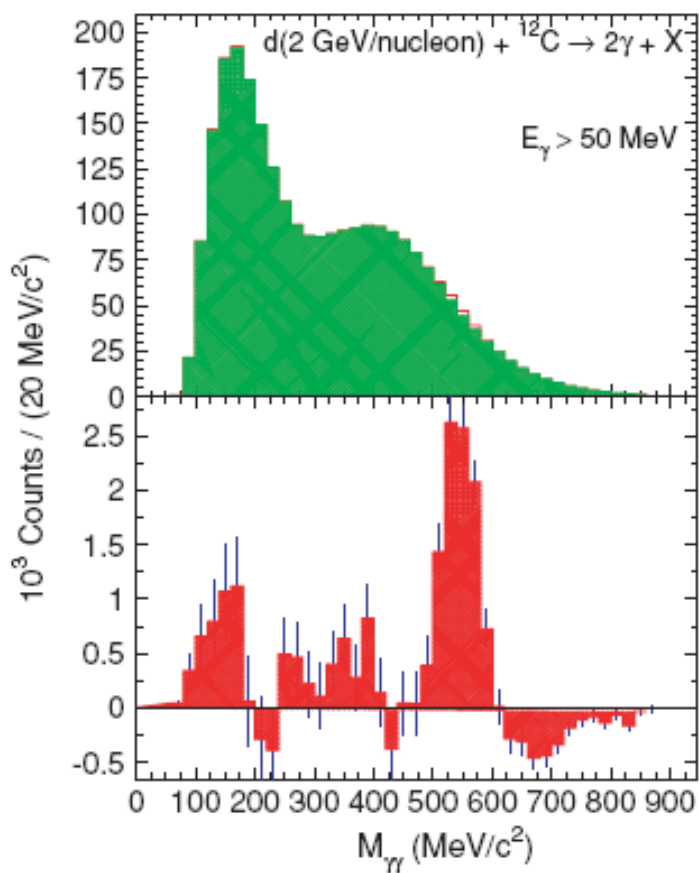

Распределение кластеров по числу модулей в кластере при двух уровнях отбора по доле энергии в центральном модуле. Данные на нуклотроне (средняя энергия γ -квантов 0.51 ГэВ) сравниваются с данными, полученными на Синхрофазотроне (средняя энергия γ -квантов 1.50 ГэВ) и с результатом моделирования методом Монте Карло (средняя энергия γ -квантов 1.50 ГэВ).

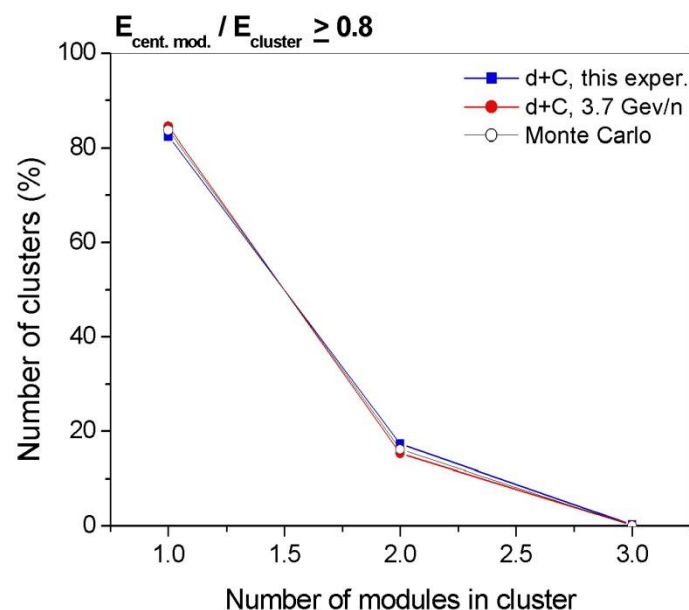
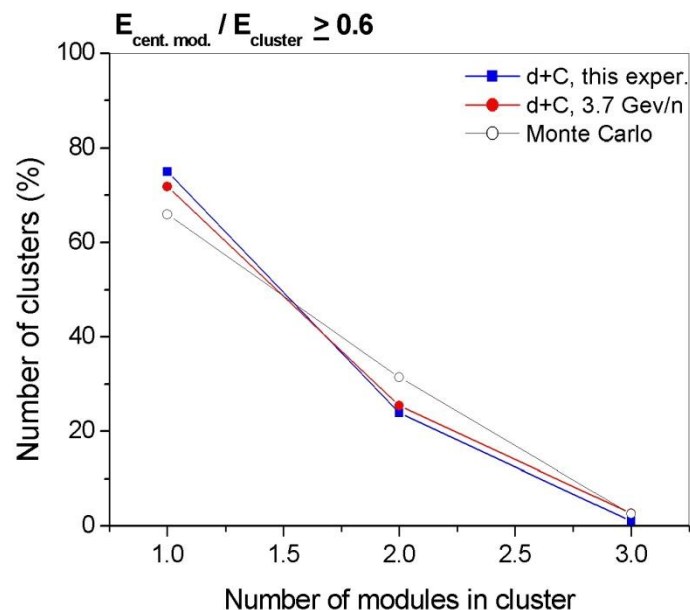

Отношение энергии в центральном (с максимальной энергией) модуле на вторую по величине энергию в модулях. Квадратиками обозначены экспериментальные данные, кружочками представлены данные, полученные с помощью моделирования методом Monte Carlo. Нормировка по полному числу γ -квантов.

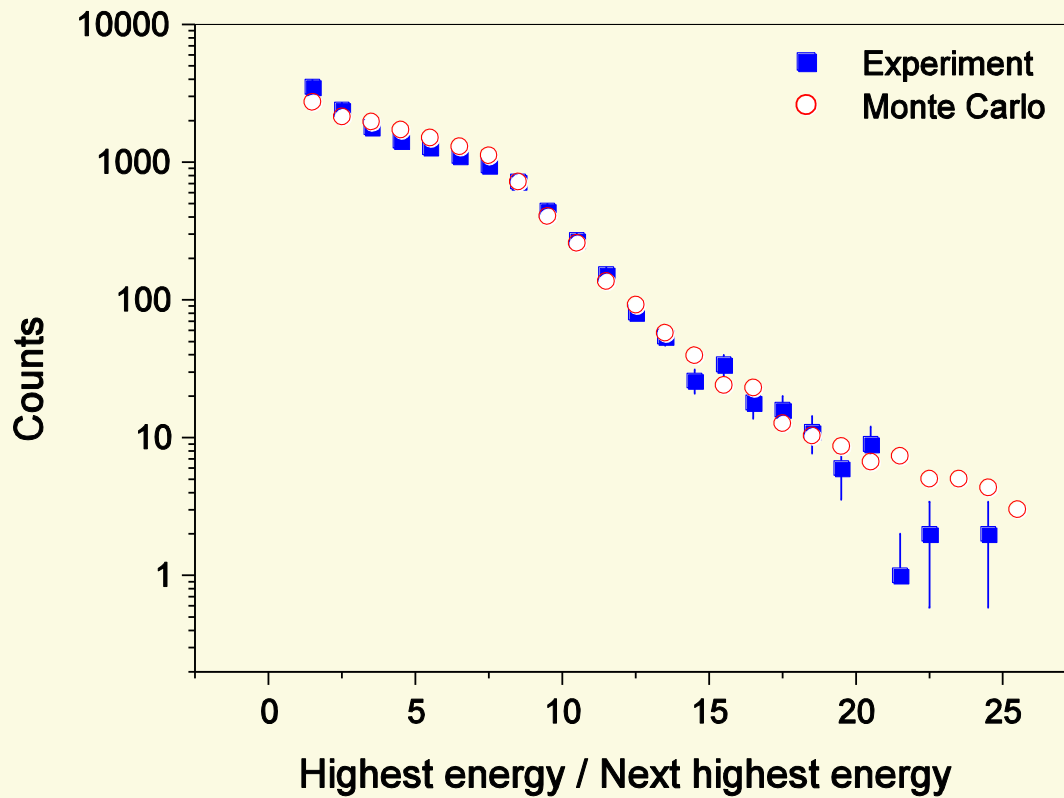

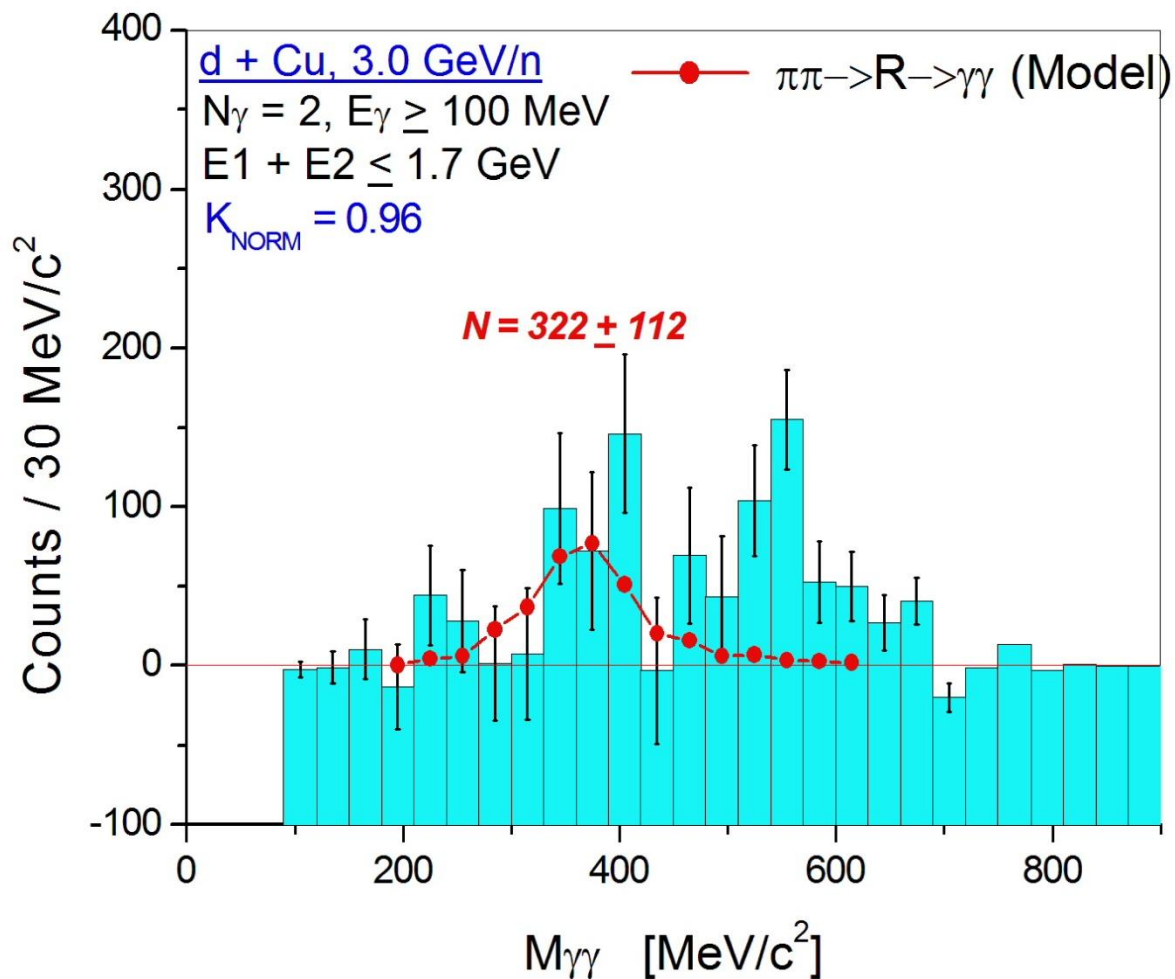

Распределение по инвариантной массе пар $\gamma\gamma$ после вычитания фона в реакции $d+\text{Cu}$ (3.0 ГэВ/нуклон) при условиях отбора: $N_\gamma = 2$, $E_\gamma \geq 100 \text{ МэВ}$, $E1+E2 \leq 1.7 \text{ ГэВ}$.

Регистрация жестких π^0 -мезонов (с энергией $E > 1.2$ ГэВ)

в одном плече двухплечевого γ -спектрометра

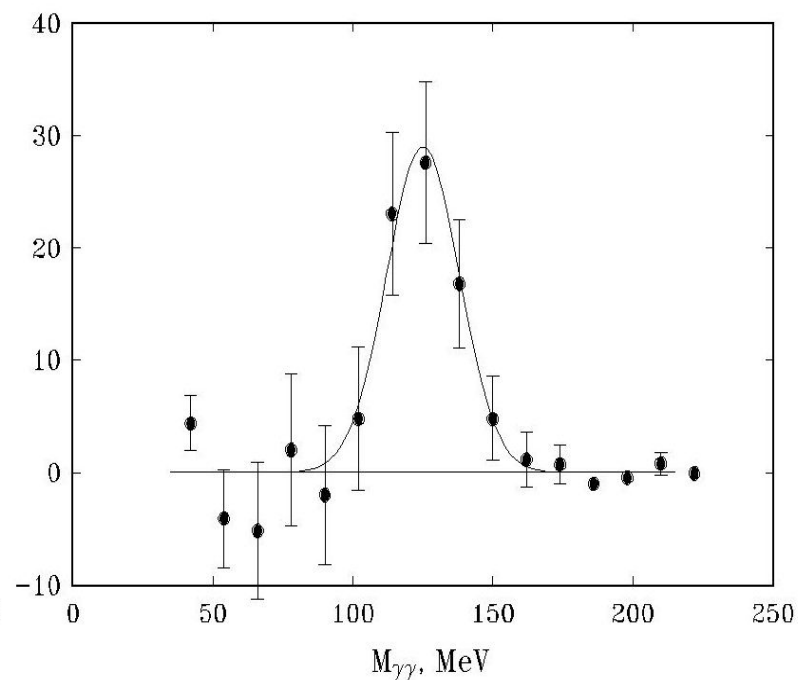
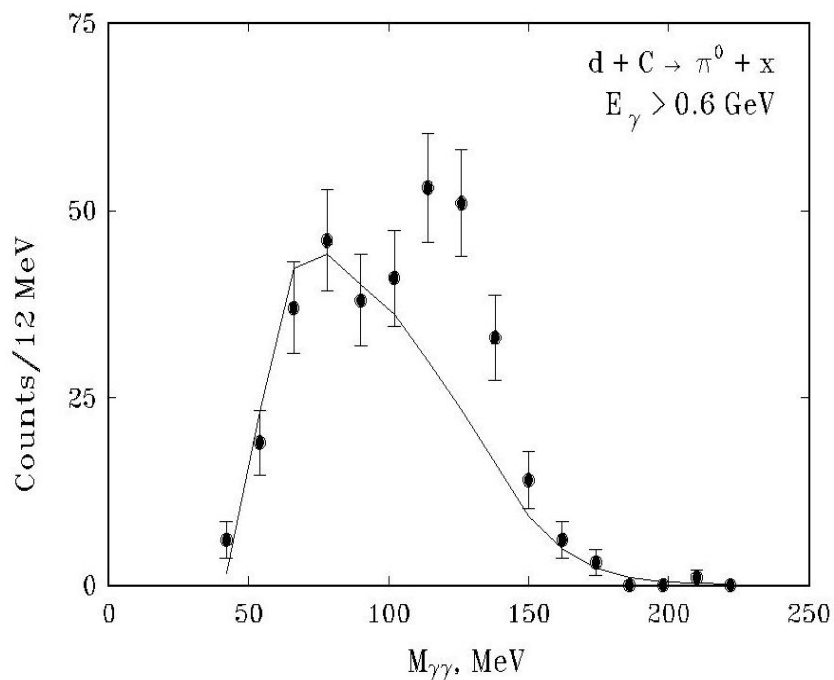

Invariant mass distributions of $\gamma\gamma$ pairs from the dC reaction. The top shaded histograms show the background contribution. The bottom histograms are invariant spectra after the background subtraction.

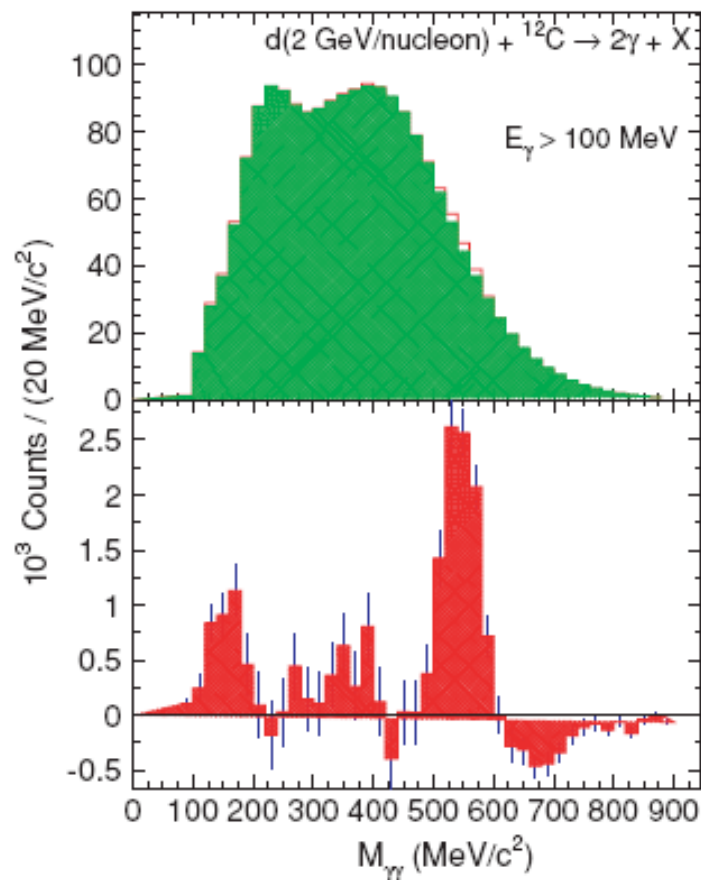
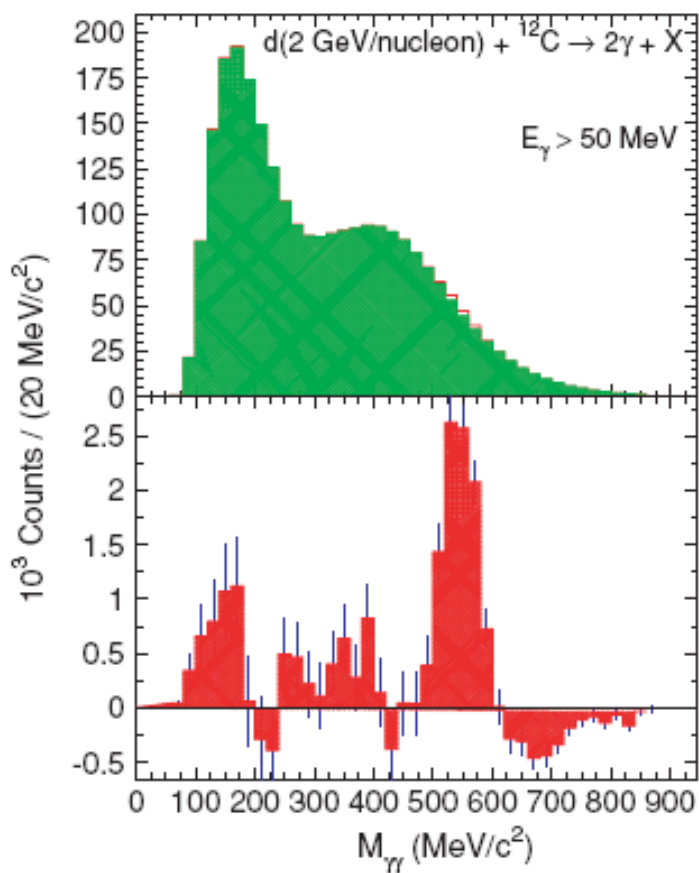

$$E_{\gamma} \geq 100 \text{ MeV}$$

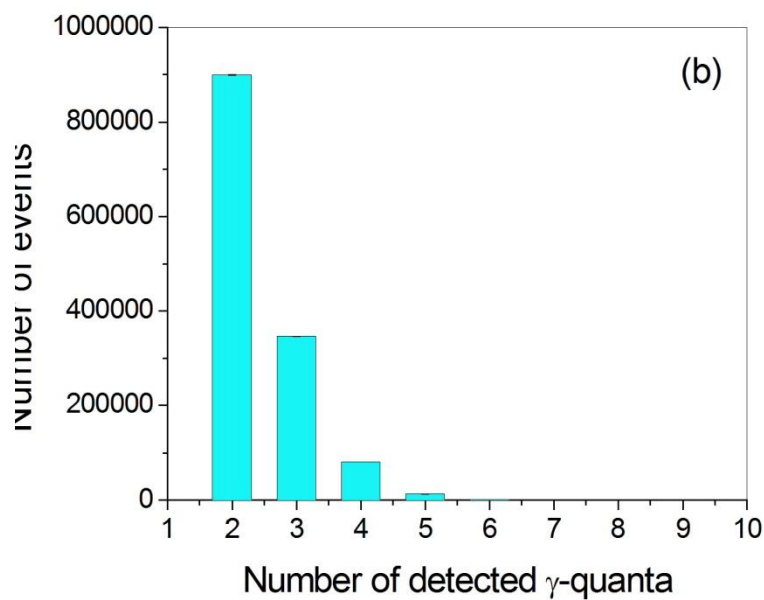
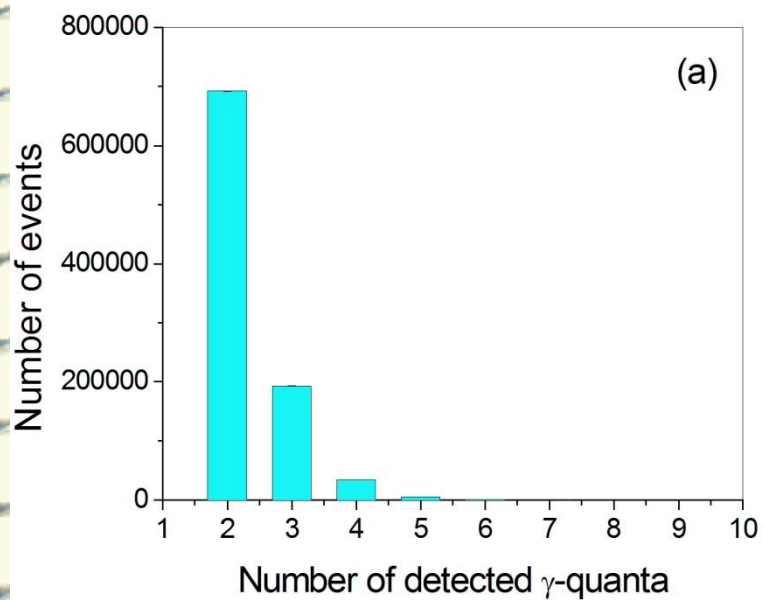

Energy distribution of γ -quanta in the d+C

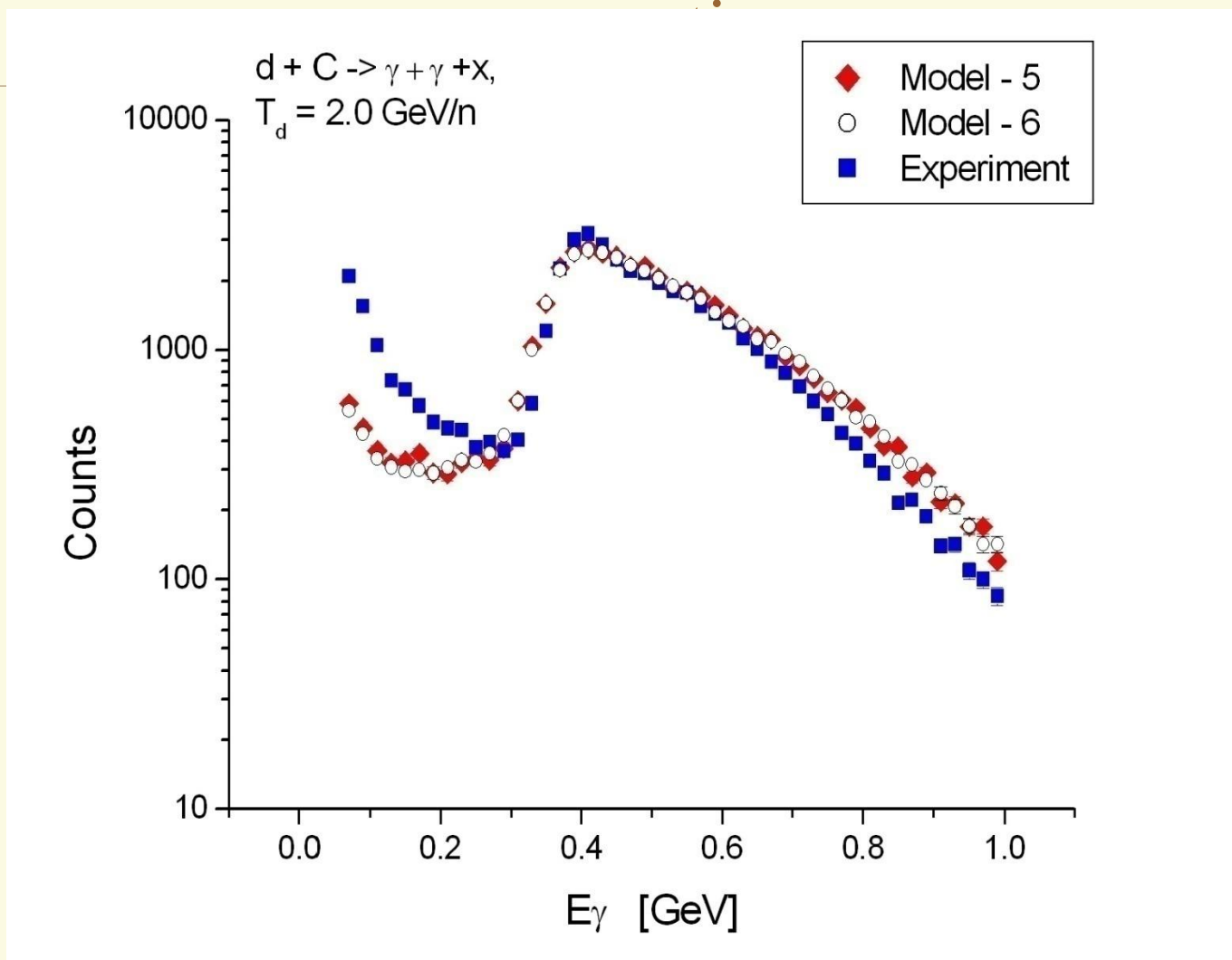

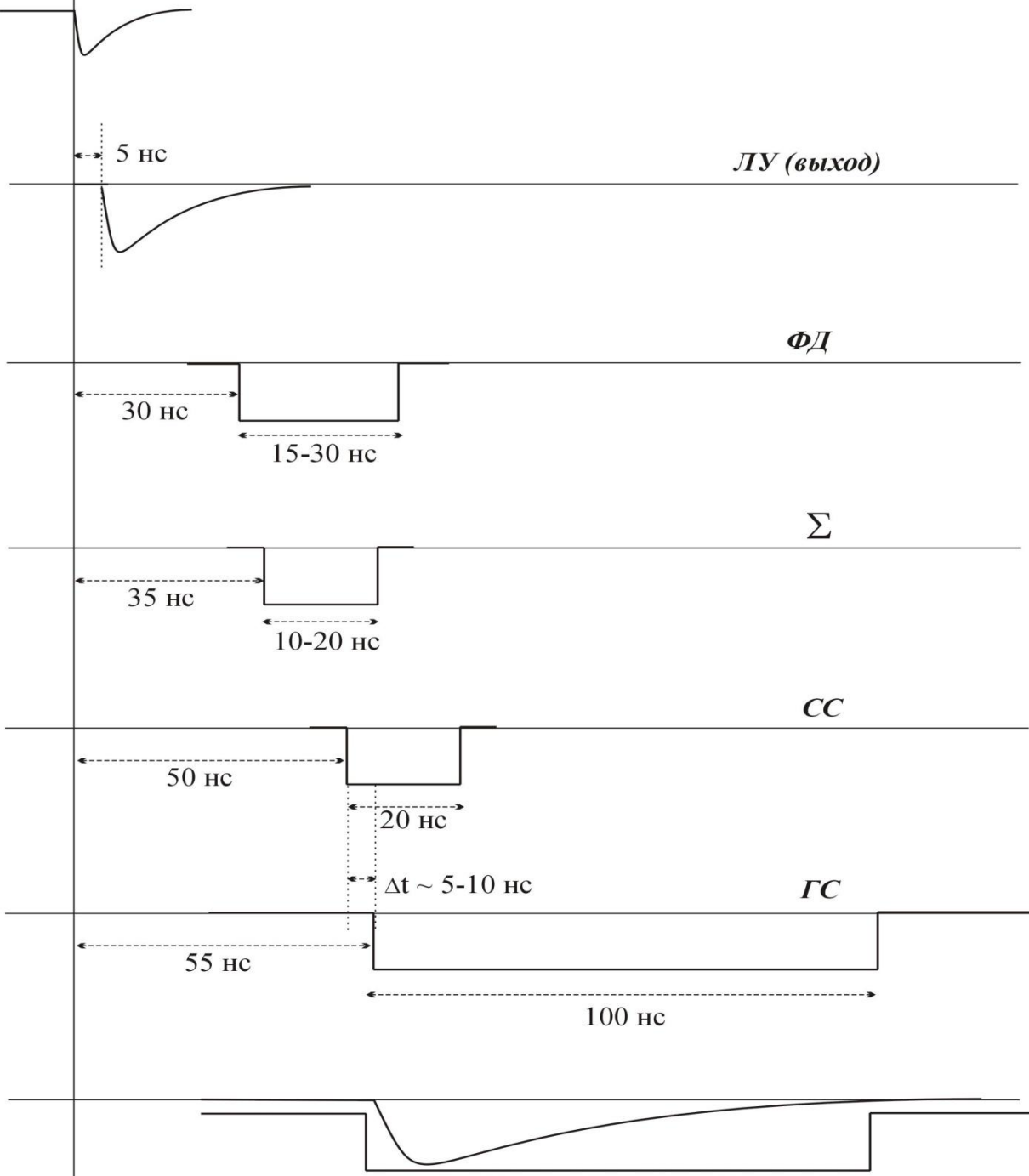

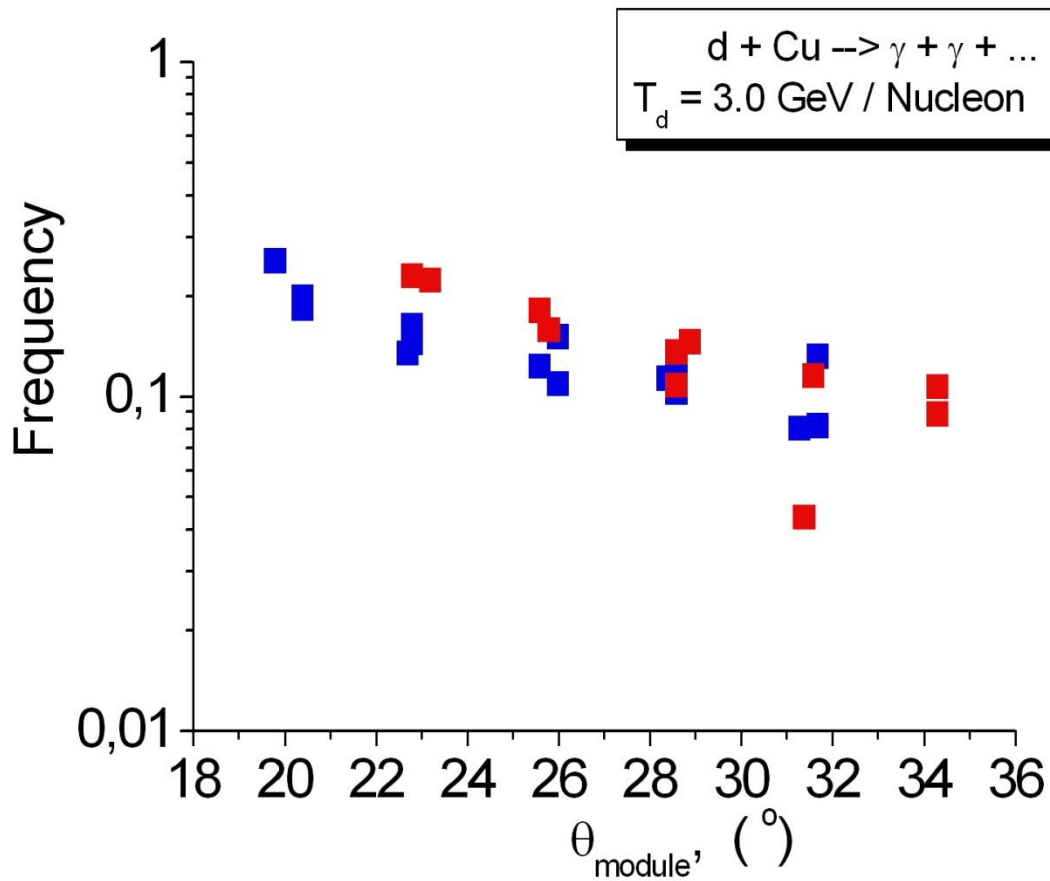

$\omega(\rho) \rightarrow ee$ and $\phi \rightarrow ee$ detection

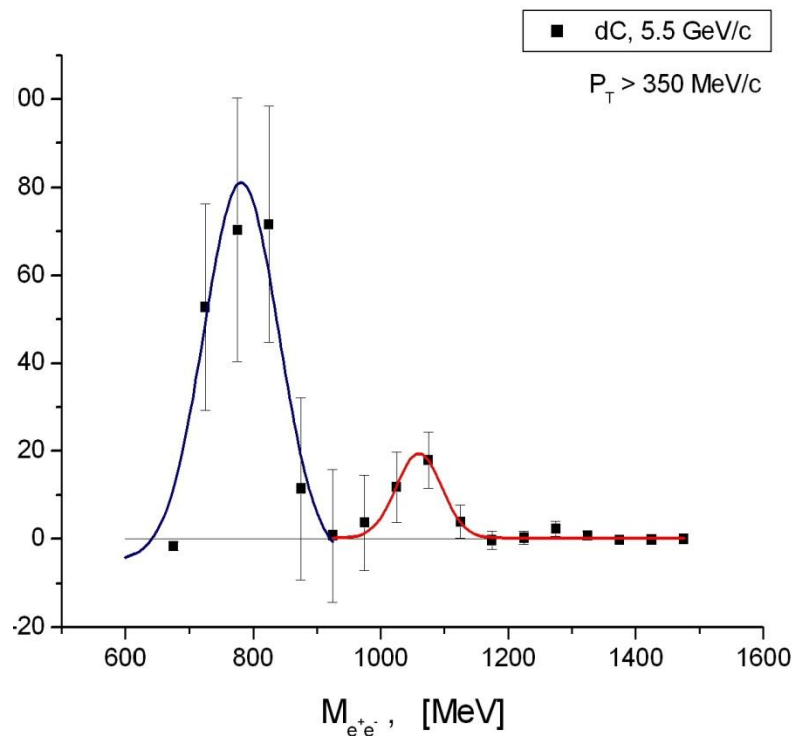
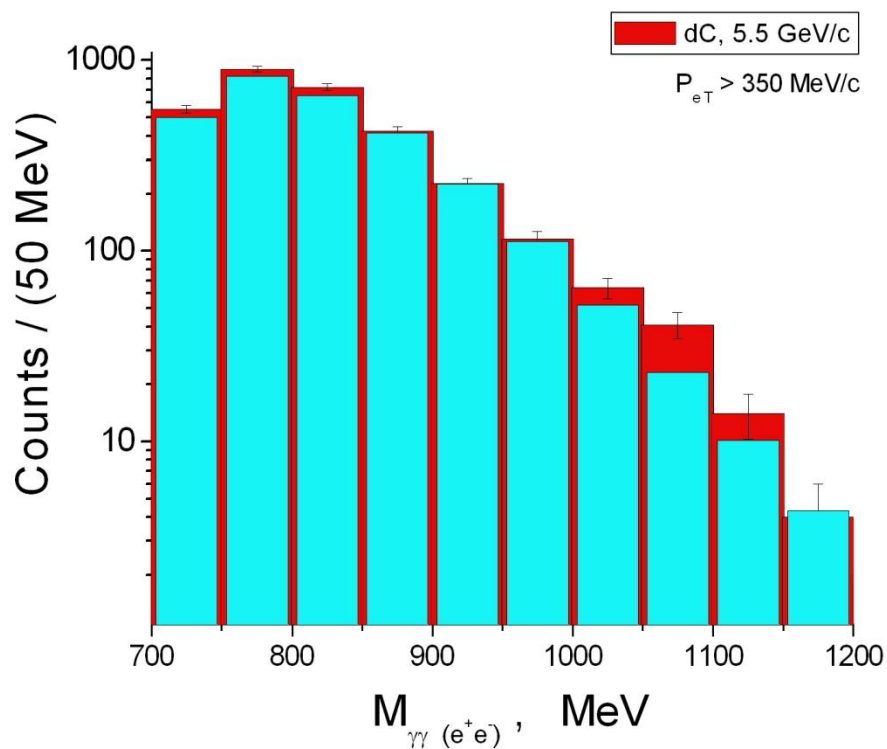

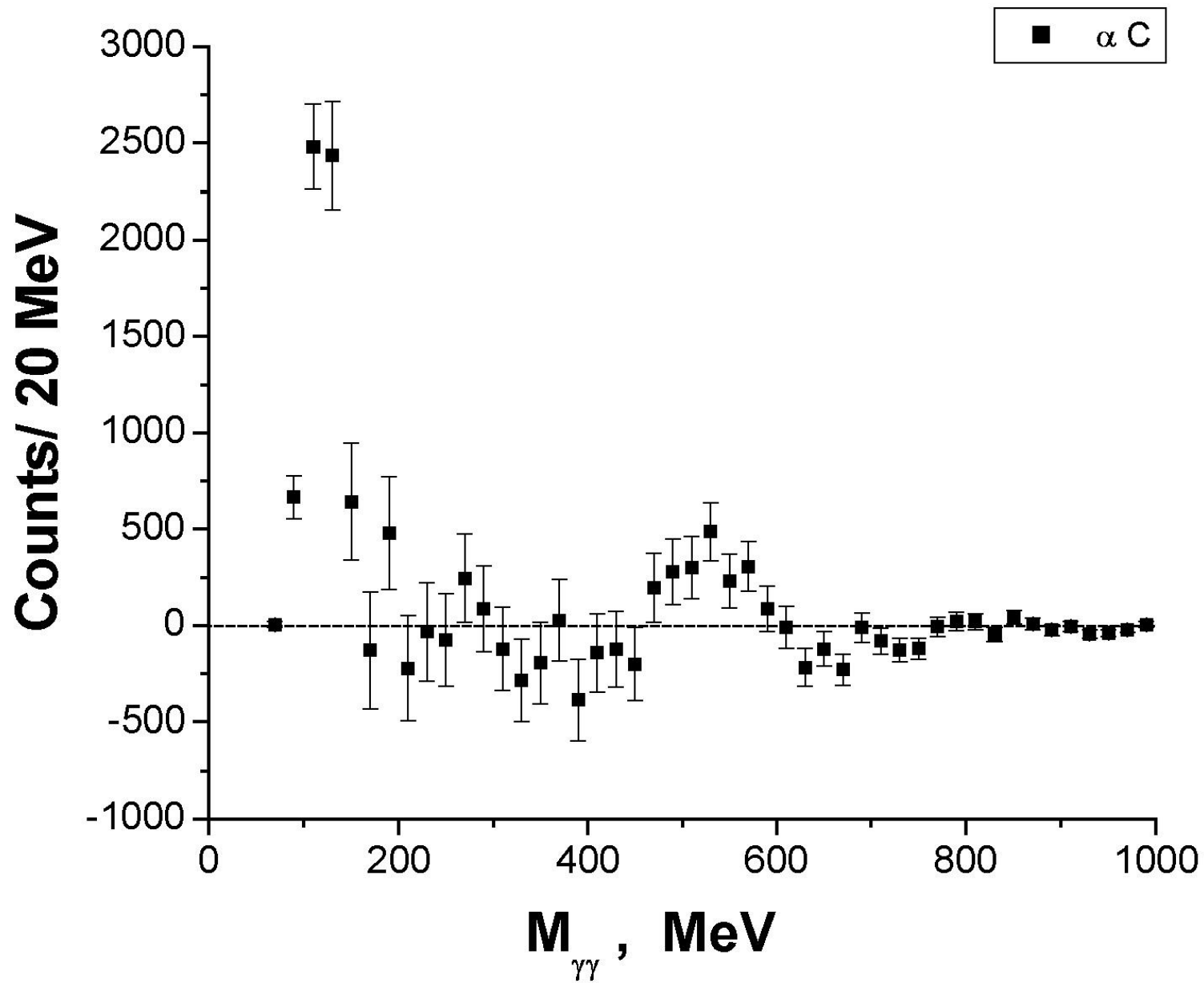

The multiplicity of detected photons in dC-collisions at 2.75 GeV/c per nucleon

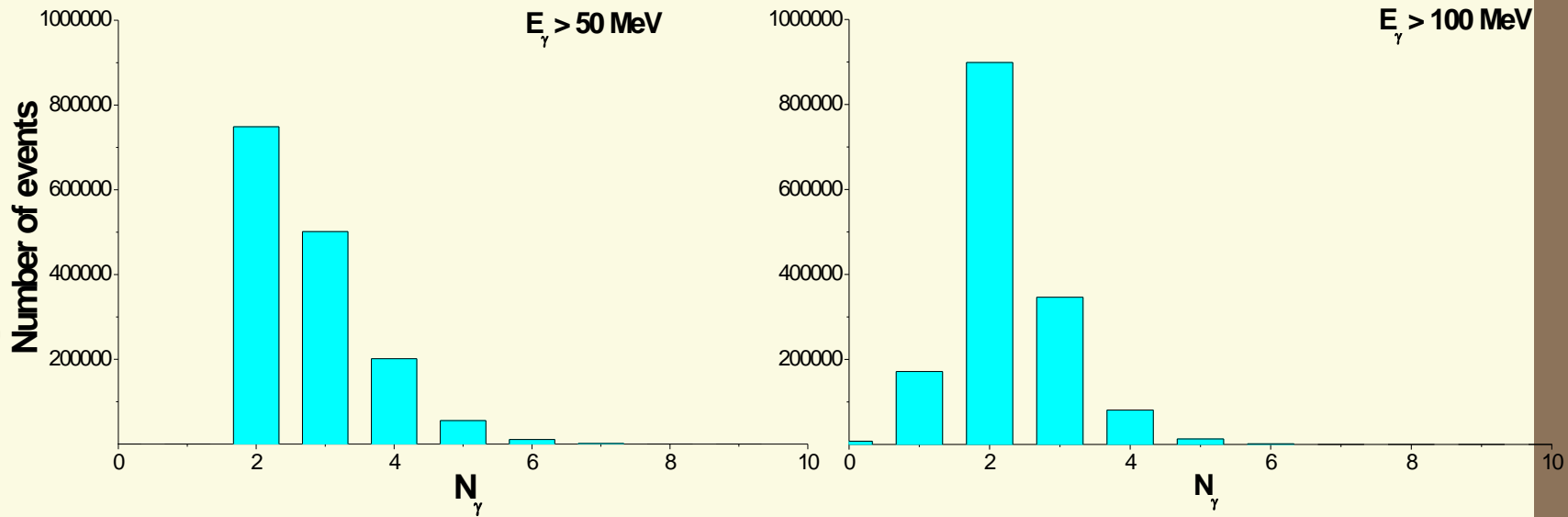

Preliminary

Distribution of the opening angle of $\pi^0\pi^0$ pairs

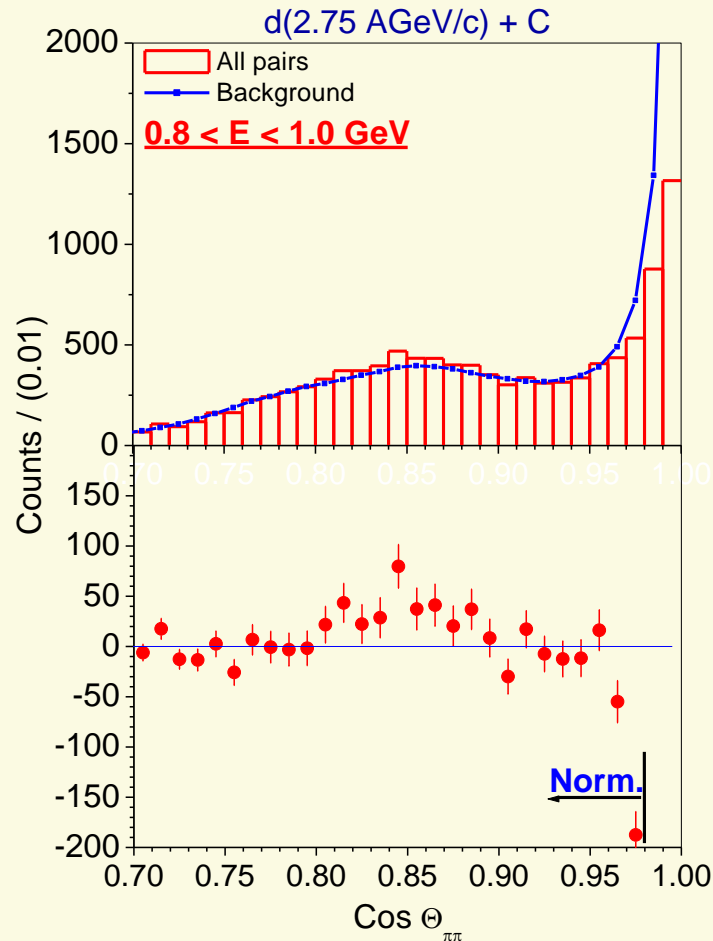

The invariant mass spectra of two π^0

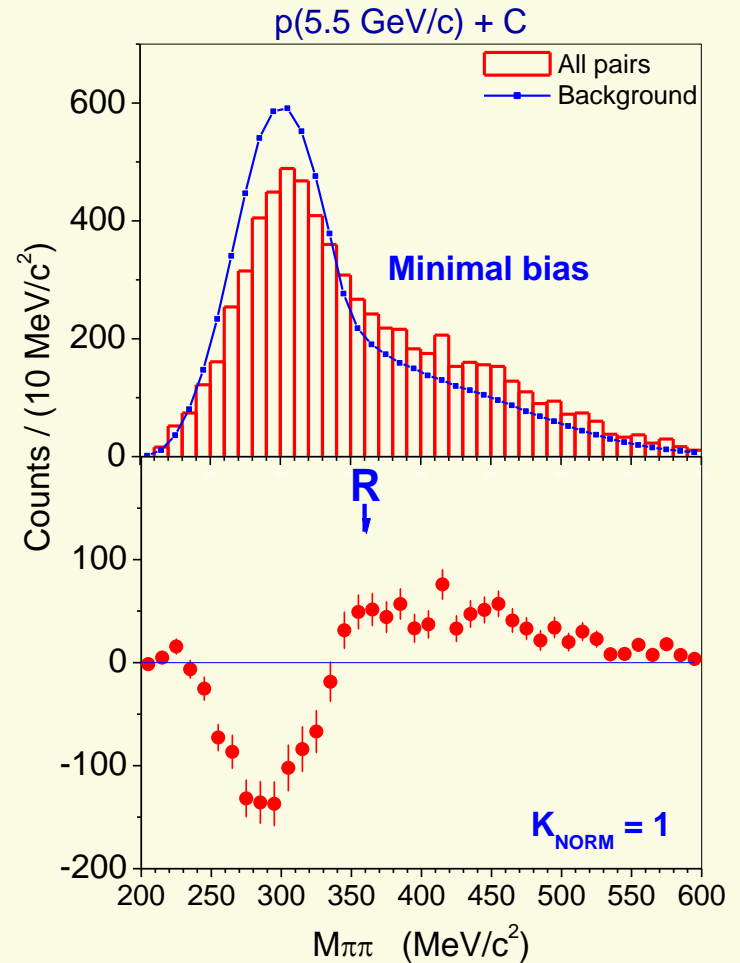
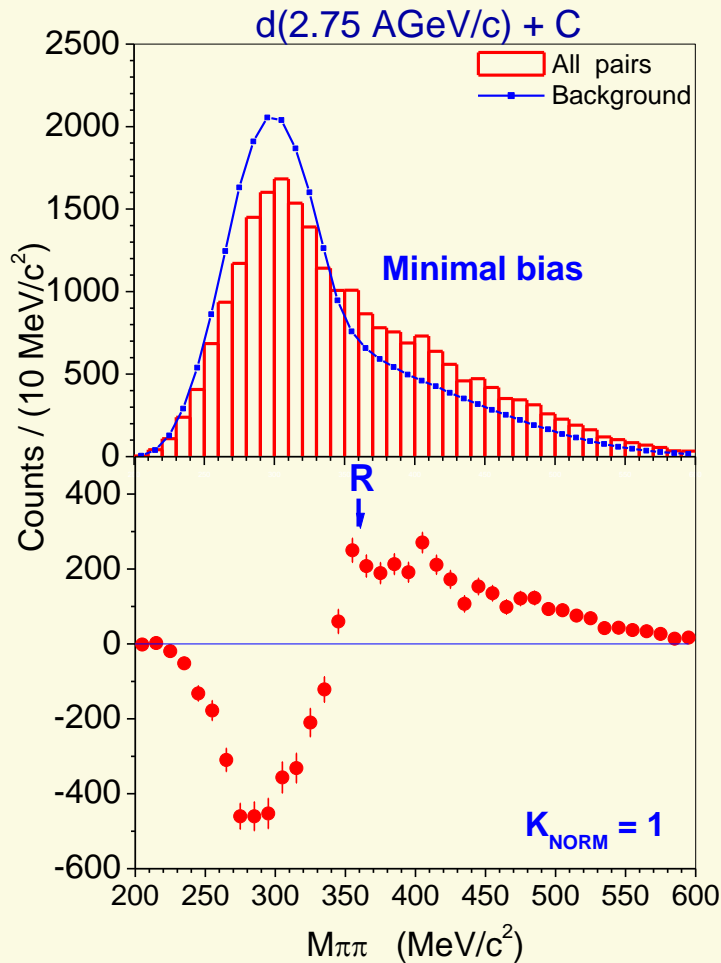

The invariant mass spectra of two π^0

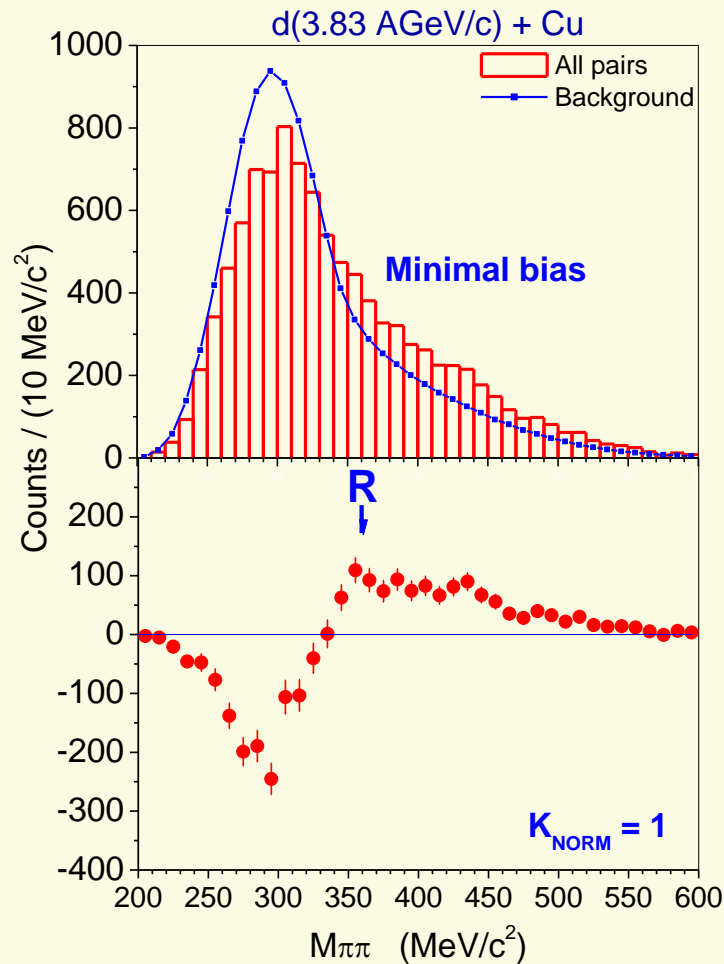

Abstract

- Along with π^0 and η mesons, a resonance structure in the invariant mass spectrum of two photons at $M_{\gamma\gamma} = 360 \pm 7 \pm 9 \text{ MeV}$ is observed in the reaction $dC \rightarrow \gamma + \gamma + X$ at momentum 2.75 GeV/c per nucleon.
- The resonance structure is not observed in pC collisions at the beam momentum 5.5 GeV/c.
- The data obtained in the $d+C$ reaction is confirmed by $d+\text{Cu}$ experiment at 3.83 GeV/c per nucleon.
- There are strong indications that the resonance exists in the $\pi^0\pi^0$ system.

Acknowledgements

We thank S.B.Gerasimov, E.E.Kolomeitsev, and E.A.Strokovsky for fruitful discussions and reading the manuscript. We are grateful to A.S.Danagulyan, H. Machner, V.D.Kekelidze, A.S.Khrykin, V.I.Kukulin, V.A.Nikitin, A.M..Sirunyan, O.V.Teryaev, and G.A.Vartapetyan, for discussions and valuable remarks.

Furthermore, we would like to thank S.V.Afanasev, V.V.Arkipov, A.S.Artemov, A.F. Elishev, A.D. Kovalenko, V.A.Krasnov, A.G.Litvinenko, A.I. Malakhov, G.L.Melkumov, S.N Plyashkevich and the staff of the Nuclotron for their help in conducting the experiment, as well as B.V.Batyunya, A.V. Belozerov, and A.G.Fedunov, for their help in analyzing data.